

## **2024 Knoxville Raceway Rules–Sprint Cars**

3/28/2024

*Situations may arise that are not precisely covered in this rule book. All rulings and interpretations of the rules included herein will be made by Knoxville Raceway officials and these judgments will be final. a) Effective Date – The rules within this book are effective upon the date of publication.*

**2024 Rules: Last amended on:** Disclaimer updated 3/21/2023 Rules: 1.5,1.6 c,9.0,19.0 b,c Procedural rules-31.4, 32.3, 32.5, 35.0, 35.1, 37.4,45.0,46.0 3/27/2023 Tire penalties, 7.24 6/29/2024, Weight rule addition,1.2, illustration pg. 46 all tubing rule, no Tungsten tubing,

### **Disclaimer**

The rules and/or regulations set forth herein are designed to facilitate the orderly conduct of racing events and to establish minimum acceptable requirements for such events. These rules shall govern the conditions for all events, and by participating in these events, all participants agree to comply with these rules and regulations. NO EXPRESS OR IMPLIED WARRANTY OF SAFETY SHALL RESULT FROM THE PUBLICATION OF, OR COMPLIANCE WITH, THESE RULES AND REGULATIONS. They are intended solely as a guide for the conduct of the sport and are in no way a guarantee against injury or death to participants, spectators, officials, or others. The Race Director shall be empowered to permit any reasonable and appropriate deviation from any of the specifications and procedures herein or impose any further restrictions that in his/her opinion do not alter the minimum acceptable requirements. Any visible equipment changes and/or performance enhancing changes to previously approved cars and/or equipment must be approved in writing prior to introduction into competition. Knoxville Raceway reserves the right to immediately determine the legality and use of any equipment that has not received prior written approval for introduction into competition.

Racing is a very dangerous sport. If there is any part of the race program that causes you concern

for your personal safety or for any member of your crew, you should bring those concerns to the attention of the Competition Director and or the Race Director. If after doing so those concerns are not met you should consider withdrawing from competition until review can be made through the appeals process.

We all have the same obligations to try and make this facility as safe as possible. We do appreciate your comments in this area.

NO EXPRESS OR IMPLIED WARRANTY OF SAFETY SHALL RESULT FROM ANY SUCH DEVIATION OR RESTRICTION OF THESE SPECIFICATIONS, RULES OR PROCEDURES. Any interpretation of, or deviation from, these rules is left to the discretion of race officials. THEIR DECISION IS FINAL.

*Situations may arise that are not precisely covered in this rule book. All rulings and interpretations of the rules included herein will be made by Knoxville Raceway Officials and these judgments will be final.*

*Amendments and or updates may be made to these rules at any time; no changes or additions will affect the intent or decisions based upon these rules prior to any amendment*

**Knoxville Raceway Officials may refuse to allow a participant to compete in an event if it is determined at their discretion that any advertising and/or sponsorship or similar agreement is detrimental to the sport, the track, including the image of the sport.**

**c) Failure to comply with any of the above rules may result in a loss of Point Fund monies, purse monies and/or any other penalty as deemed necessary Knoxville Raceway Officials.**

**By participating at Knoxville Raceway, all participants are signifying that they agree to comply with these rules and regulations.**

## INDEX

- 1.0-CHASSIS
- 1.2-WEIGHT RULE (Illustration, pg. 46)
- 1.3-ENGINE RULES (410)
- 1.4-FUEL TANKS
- 1.5-TIRE RULE (410)
- 1.6-WINGS (410 TOP WING)
- 1.7-410 TOP WING SIDE PANELS
- 1.8-FRONT WING ALL CLASSES
- 2.0-INTENTIONALLY LEFT BLANK
- 3.0-360 SPRINTS
- 3.1-12-360 HEADS
- 3.13-FUEL INJECTION
- 3.14-SHOCKS
- 3.16-360 CLASS WINGS
- 4.0-INTENTIONALLY LEFT BLANK
- 5.0-PRO SPRINTS
- 5.6-PRO ENGINES
- 5.8-PRO TIRE RULE
- 5.10-5.18 Pro Series WING RULE
- 7.00-SAFETY AND TECHNICAL INSPECTION
- 7.1 FIRE SUPPRESSION SYSTEMS
- 7.2 ELECTRONICS, GAUGES AND DASHES
- 7.3-BOLTS
- 7.4-SHOCKS
- 7.5-TORSION BAR
- 7.6-TORSION ARM STOPS
- 7.7-BATTERIES and RADIOS
- 7.8-NUMBERS
- 7.9-MUFFLERS/HEADERS
- 7.10-BRAKES
- 7.11-WHEELS
- 7.12-TIRES
- 7.13-BUMPERS & NERF BARS
- 7.14-FRONT AXLES
- 7.15-TETHERS
- 7.16- INTENTIONALLY LEFT BLANK
- 7.17-HOODS
- 7.18-BODY SIDE PANEL
- 7.19-DRAG LINKS
- 7.20-FLOOR PAN
- 7.21-CARBON FIBER
- 7.22-WING POSTS
- 7.23-TRACTION CONTROL DEVICES
- 7.24-DRIVELINE SYSTEMS
- 7.25-SEATBELTS
- 7.26-DRIVER'S EQUIPMENT
- 7.27-CAR'S EQUIPMENT
- 7.28-SEATS

8.0- INTENTIONALLY LEFT BLANK	36.0	COURTESY LAPS
9.0- SPORTSMANSHIP/	37.0	SINGLE FILE REALIGNMENTS
9.1- APPEAL OF FINES	38.0	RED FLAGS
9.2- FINES	39.0	BACKUP CARS
9.3-TECHNICAL INSPECTION	40.0	DRIVER CHANGES
10.0-SAFETY INSPECTIONS	41.0	ALTERNATES
11.0-SCALING PROCEDURES	42.0	FUEL STOPS
12.0-INTENTIONALLY LEFT BLANK	43.0	EQUIPMENT & SAFETY CHECKS DURING RACE EVENTS
13.0-INTENTIONALLY LEFT BLANK		
14.0-PROTESTS	44.0	RADIOS
14.8-PROTEST FEES	45.0	PAYOUT
15.00-TIRE PROTESTS/TIRE PREPPING PENALTIES	46.0	RE SCHEDULED EVENTS
16.0-ALCOHOL AND DRUG POLICIES	47.0	IMAGES on pages 47,48
17.0-ADVERTISING AND RELEAS		
18.0-MINIMUM AGE REQUIREMENTS		
19.0 POINTS		

## **2024 PROCEDURAL RULES**

30.0	DRIVERS MEETING
31.0	TIME TRIALS/PIT INCIDENTS
32.0	PACE CAR AND STAGING
33.0	HEAT RACES
34.0	THE START
35.0	YELLOW FLAG

## 1.0-410 Sprints (410.00)

### **\*\* These rules pertain to all classes.**

**1.1-CHASSIS\*\***-Any sprint chassis is allowed, but it must pass any test prescribed by the safety inspectors. The roll cage must be of a four-post design. Sprint cars only. Wheelbase no less than 83" and no more than 90". No elliptical tubing used on or as part of the main frame structure. Slip-tubing is not allowed in the chassis construction. This includes safety bars. Any existing slip-tubing must be replaced or welded.

The following measurements are minimum, suggested material: ASTM4130 normalized.

TOP RAILS: 1 ½" x .095

BOTTOM RAILS: 1 3/8" x .095 or 1 ½ " x .083

ROLL CAGE UPRIGHTS: 1 3/8" x .083

ROLL CAGE TOP CROSS MEMBERS: 1 ½" x .095

UPPER RAILS: 1 3/8" x .083

REAR END SAFETY BAR (mandatory): 1" x .083 or 1 ¼" x .065

BRACE: 1 ¼" x .065

### **1.1 A Chassis Support bars\*\***

All chassis are required to have additional bars installed to support and decrease the span between the front and rear uprights in the driver's area. The support bars must be in addition to the front and rear uprights. Any attempts to manipulate the front and rear uprights to conform to these measurements will not be allowed. These additional bars will be minimum 1.375 X .083 ASTM4130 normalized steel or equivalent material as per Knoxville Raceway current rule 1.0. Left and right side support bars may be one of the three designs below. Left and right side support bars do not have to be of the same design. Right side body opening shall remain the same per rule 7.18, A, Knoxville Raceway Rules 2020.

Left and right side support bars may be one of the three options:

1. Support bar may be designed similar to what was known as a "safety bar". It must be attached to the top rail at a point 15" to 20" from the rear of the front upright. It must attach to the hip rail and have a gusset attached to the rear upright near a point opposite of the rear brace/shock mount bar. The curve must be between 4" and 7" measured from outside of the rear upright tube to the outside of the support bar. See Diagram #16.12.1.
2. Existing chassis with a left side support bar installed (formerly called safety bar) that do not meet the option one specification above, may add a gusset that attaches to the top rail 15" to 20" from the rear of the front upright and angle to the support bar. The existing support bar tubing must

meet the minimum as described above (1.375 X .083 ASTM4130 normalized steel or equivalent material). See Diagram #16.12.2.

3. A support bar may be added to the top rail at a point 15" to 20" from the rear of the front upright and to the rear upright near a point of the rear brace / shock mount bar but no higher than 7" above the hip rail. This bar may have a slight curve near the rear upright to accommodate elbow room and ease of fitment. See diagram #16.12.3. **No additional anti roll/weight transfer bars on the racecar.**

**1.2-WEIGHT RULE** – Weight rule for the 410 class is 1425 lbs, including the driver, at the conclusion of the race. Cars not making weight will be penalized to last in that event. Additional bolt-on weight will be permitted. Weight pieces must be mounted and fastened to the frame and/or chassis in a secure manner. Weight pieces weighing 15 lbs. or less must be bolted using at least one 3/8" diameter grade 8 or better bolt minimum. Weight pieces weighing more than 15 lbs. must be bolted using at least two 3/8" diameter grade 8 or better bolts minimum. All additional bolt-on weights must be mounted and fastened in the area between the bottom frame rails and axles and no higher than the upper rails. All bolt-on weights must be painted white. All bolt-on weight and mounting is subject to Knoxville Raceway Officials approval. Loss of any bolt-on weight during competition shall result in disqualification from that event. Failure to follow any of the above restrictions and procedures may result in fines, disqualification and/or other penalties.

Titanium front axles, nerf bars and bumpers will not be permitted. Nerf bars and bumpers must be made from magnetic steel and/or stainless-steel tubing and securely bolted to the chassis. Left and Right Nerf bars must attach to the chassis at three points. The nerf bars must not extend past the outside edge of the tires. The bumpers must be a minimum of 1.00" in diameter tubing and have a minimum material thickness of .065 inches or a maximum material thickness of .095. Tubing may not be filled with the purpose of adding weight to the chassis. No Tungsten tubing allowed.

### **1.3-ENGINE RULES**

**A.** Only small block V-8 engines with the cam in the block and a maximum of 410.00 cubic inches of displacement (tolerance + 0.000) will be permitted. The formula  $6.2832 \times \text{bore}^2 \times \text{stroke}$  will apply. Big block engines will not be permitted.

**B.** The engine must be mounted in-line with the driver and the driveline must pass beneath the driver on center through the driver's compartment. Offset engines and/or offsetting the position of the engine will not be permitted.

**C.** The engine block and cylinders must be machined from cast aluminum. Billet machined blocks and/or cylinder heads will not be permitted.

**D.** Engines with the magneto and/or distributor in a forward mounted and/or front mounted position must be approved prior to competition.

- E.** Only normally aspirated engines will be permitted. Turbo chargers, super chargers and/or forced induction of any type and/or description will not be permitted.
- F.** The maximum engine cylinder bore size shall be 4.165.
- G.** All engine cylinder sleeves (inserts) must be machined from an iron and/or steel alloy.
- H.** Titanium crankshafts, connecting rods and/or rod caps will not be permitted.
- I.** Only two (2) valves and one (1) spark plug will be permitted per cylinder.
- J.** Cylinder heads must retain a traditional valve pattern. Rotation of the valves will not be permitted. Cantered or splayed valve cylinder heads must be approved prior to introduction into competition.
- K.** Only steel connecting rods with a maximum length of 6.000 inches will be permitted.
- L.** All oil pans must have an inspection plug. The inspection plug must be a #12AN fitting or 1.00" pipe plug. If an engine does not have an inspection plug the oil pan must be removed for inspection prior to competition.
- M.** Only throttle plate (butterfly) and shaft throttle body styles with round circular bores will be permitted. The maximum throttle bore as measured at the throttle plate (butterfly) may not exceed 3.000 inches in diameter. Slide plate, rotary cylinder, and/or other styles must be approved prior to competition. Carbon Fiber manifolds and/or any other injection type pieces manufactured from carbon fiber will not be permitted. (Does not include stacks).
- N.** A maximum of only 16 fuel nozzles, utilizing two (2) per cylinder will be permitted. One (1) nozzle must be placed in the cylinder head and one (1) nozzle must be placed in the injector. In-cockpit fuel shut off valves should be clearly marked as to on and off position.
- O.** A minimum of two (2) throttle return springs must be used to mechanically return the throttle to a fully closed position.
- P.** Only magneto-type ignitions will be permitted. A single crank-trigger type system will be permitted as a backup ignition system. One (1) switch that alternates the current between the magneto and the crank trigger may be mounted to the dashboard within the driver's reach. Multiple coil-pack ignitions will not be permitted.
- Q.** Steel and stainless steel headers will be permitted. Titanium headers will not be permitted.
- R.** If there are new engine components and/or a new engine configuration they must be submitted for approval to Knoxville Raceway prior to being introduced into competition.

#### **1.4-FUEL TANKS\*\***

- A. The same fuel cell/tank must be used in the same car for the entire race program. The fuel cell/tank may be changed at the discretion of Knoxville Raceway Officials. Fuel tanks must be securely fastened. Any means of mounting the tank must meet the approval of the officials. A fuel cell with bladder and foam will be the only type of fuel cells permitted. The fuel cell must be of one piece construction of cross-link polyethylene plastic. **Alterations and modifications will not be permitted.**
- B. All teams racing at Knoxville Raceway will be encouraged to run a 33+ gallon fuel tank and bladder. At all events 33 gallons of fuel will be considered as part of the formula utilized when determining the total number of laps prior to refueling.
- C. Fuel additives, including but not limited to nitro, nitro methane and/or nitrous oxide injection will not be permitted. Pure methanol and/or other approved fuels will be permitted. Fuel samples may be taken from time-to-time for inspection and analysis.

**\*\*1.5-TIRE RULE 410 CLASS \*\*D12A, D15A, New mediums will be the only tires allowed starting June 14<sup>th</sup>, 2024 and the April World of Outlaws show.**

A. Hoosier Racing Tires on all four corners:

**Fronts:** 85/8.0-15 D12, D15, D20

**Left Rears:** 15.0/90-15 \*\* H12, 15.0/92-15 H12, H15, 15.0/94-15, H12, H15 15.0/95-15 H12, H15, 15.0/96-15, D12A,

**Right Rears:** 105/16.0-15 H15, Medium, D15A, New tread design Medium

B. No tire prep chemicals or tire softeners allowed. See section 15.2

C. **\*Until further notice 2024 Right Rear Tire rule: New tires will be marked in time trials only. Approved used tires may be run anytime during the event if they are stamped by Knoxville Officials before Hot Laps each night at the tech area.**

Time Trials, Qualifying Heat and A Feature. Any unapproved tire change between events will result in the car going to the rear of the next event. Cars competing in the B or C mains or extra dashes etc. may use different legal tires. Cars transferring from the B main to the A main must use the tire they qualified on (time trials/heat) to keep their transfer position. Procedural rules regarding tire changes and other information will also be posted at all events **and may be amended at any time.** Tire use rules may be changed according to the rules of the sanctioning body for that event, providing Knoxville Raceway Officials approve the changes.

D. Right rear wheels may be changed using the same tire without penalty.

E. Knoxville officials will mark tires after time trials. Any tampering with the stamp will result in disqualification.

F. In the event track conditions warrant, and or special races, Knoxville Officials may waive the tire rule for the evening's program.

- G. In the time between time trials and the start of heat races a punctured, damaged, sliced and/ or out of round marked right rear tire may be replaced with a new tire of the same size and compound without penalty. Replacement tires will be remarked by the Knoxville Officials and the replaced tire shall be confiscated. Non-repairable punctured, sliced and/or out-of-round marked right rear tires may be changed to a used right rear tire of the same size and compound. (Preferably a previous marked tire) The damaged right rear tire will be impounded for inspection. Knoxville Officials must approve this change. Cutting or further damaging the tire in question may result in additional penalties. If a marked or acceptable used tire is not available, then a tire of a harder compound may be substituted. (105-16 H20 or Medium). This rule does not apply after any event has started. Any tire changes after the green flag will result in the car going to the rear of the lap they are running on.
- H. Tire rules are in effect for all classes. Cars may not race with a flat tire on the right rear, left rear or right front. Wheels down on the sidewall against the track are considered flat. Left front tires that are off the bead will be sent to the work area.
- I. **Chemical Treatment of Tires: Hoosier Racing Tire and Knoxville Raceway strictly forbids any chemical alteration of the tire carcass and/or tread compound such as tire "soaking" or use of tread "softener." Hoosier Racing Tire strictly forbids the physical defacement (removal, altering or covering) of tire sidewall markings in any manner. Failure to comply with this warning could result in premature or catastrophic tire failure and may result in SERIOUS PERSONAL INJURY OR DEATH. (See section 8.0)**

## 1.6-WINGS 410 Top Wing

- A. Center Foil maximum size of 25 square feet with a maximum width of 60 inches. Center Foil must be square or rectangular in shape with all 4 corners set at 90 degree angles with no variance allowed. Center Foil top is to be flat from front to back and side to side.
- B. Center Foil shall be fully sheathed in aluminum. Vent holes, dimples, ridges, etc. are strictly prohibited anywhere on the wing.
- C. **Maximum 2" removable wicker bill may be mounted on the rear edge of the center foil. (Knoxville Point Shows Only) (2" Wicker bills may not be allowed when racing with different sanctioning bodies) Wicker bill must be 90 degrees to the top of the Center Foil. No built-in wicker bills or gurney lips allowed.**
- D. The top wing can be cockpit/driver adjustable. Other than the slider mechanism, no moving parts permitted on or in foil structure. Only one slider mechanism allowed on top wing, allowing adjustment forward and backwards only.
- E. Center Foil thickness cannot exceed 9 inches. Underneath side of Center Foil must appear to be a continuous smooth arc with no recesses, concaves, or protrusions. Center Foil must be one-piece construction. No split or bi-wings will be permitted. Wings must be fabricated of metal alloys only. No fiberglass, carbon fiber or other similar material may be used in the basic framework of the wings. Top wing must not extend beyond outside of rear tires.
- F. No foils or rudders will be permitted anywhere on the top wing.



G. Wing Posts\*, see section 7.22.

### **1.7-410 Wing Sideboard Panels**

A. Side panels may not be supported by braces whose section is not horizontal. All braces or supports shall be oriented thin edge to face the air stream. Only rectangular, round, or oval metal braces not exceeding 1 inch in width may be used.

B. No aero section side panel brace material allowed.

C. No brace or support shall resemble a wicker bill or a split wing.

D. Top Wing, sideboards maximum size, 72 inches long and 30 inches tall. Panels must be of one-piece construction. Panels must be fabricated flat so as to have no turnouts or flaps made of more than 2 inches of material on the front or rear of panel and no more than 1 1/4 inches on the top or bottom. Panels must be mounted parallel and square to the center foil with no more than 1 1/2" of turnout as measured from the Center Foil. Only two (2) corners on the 2/3 of each top wing sideboard will be permitted. Each corner shall be set at a 90° angle with no tolerance. The leading edge of the sideboard may not be behind the leading edge of the Center Foil.

E. Front Wing side boards maximum size, 12 inches tall and 26 inches long with no more than one inch overhang from the center foil front edge to the sideboard front edge. Sideboards may have front, back, top and bottom turnouts of no more than 1/2 inch. panels must be mounted parallel and square to the Center Foil with no more than 1 1/2" of turnout as measured from the Center Foil.

### **1.8-Front Wing: All Classes\*\***

A. Center Foil maximum size of 6 square feet with a maximum width of 36 inches.  
Center Foil must be square or rectangular in shape with all 4 corners set at 90 degree angles with no variance allowed.

B. Center Foil shall be fully sheathed in aluminum. No vent holes allowed.

C. Maximum 2" removable wicker bill allowed on any front wing. (Knoxville weekly shows only, other sanctions or may or may not allow a 2 inch wicker bill on the front.) Wicker bill must be 90 degrees to the top of the Center Foil as measured from Top of wing nose to trailing edge.

D. Maximum distance from the Center Foil front edge to the front edge of the front axle may not exceed 20 inches.

E. The Center Foil front edge must remain at least 1 inch behind the front edge of the front bumper. Center Foil top surface from side to side must remain flat.

F. Center Foil must be one piece. No split or bi wings will be allowed.

G. Wings must be fabricated of metal alloys only. No fiberglass, carbon fiber or other similar material may be used in the basic framework of the wings.

H. The Front Wing must not extend beyond outside of front tires. The Front Wing may not be cockpit or driver adjustable while the car is stationary or in motion.

I. No moving parts allowed on or in foil structure.

J. The 5" section located at the rear of the front foil must not have a bell/curl arc that is out of proportion with the rest of the front foil. As measured on a 5-inch straight edge, the belly at 2 ½ inches from the rear of the foil may not be deeper than 3/8 inch. There is zero tolerance on this 3/8-inch depth. It is suggested that the wing blueprint specify 11/32-inch depth, so that if any deflection or movement of the wing occurs, the depth will not exceed the 3/8-inch specification (This 3/8 inch measurement ensures that the belly/curl arc is gradual).

K. The belly/curl arc must span the entire length of the front foil and appear to be a gradual arc with the deepest point, no further back than 12 inches from the leading edge. The belly/curl arc must start at the front foil's leading edge and shall not exceed a depth of 2 inches. Top foil thickness cannot exceed 3 1/16 inches, 5" for flat center foils.

L. No rudders or fins on Front Wings.

**2.0-** Intentionally Left Blank

### **3.0-360 Sprints (363.6)**

**\*A. ENGINE/BLOCK** – \*Steel blocks only, If there are new engine components and/or a new engine configuration they must be submitted for approval to Knoxville Raceway prior to being introduced into competition

**B. WEIGHT RULE**-The minimum weight in the 360 class will be 1500 lbs. with the driver after a race. Tubing and nerf bars must be hollow. This rule is in effect for all 360 events. For bolt on weights and rules please refer to 410 rules as to mounting. Cars not making weight will be penalized to last in that event. \*See scaling procedures.

**C. TIRE RULE- Right Rear** Hoosier Racing Tire, stamped Medium or Hard 105 X 16, and or New tread design Medium, Medium 1

**Left Rears:** H15.0/90-15 H12, 15.0/92-15 H12, H15, 15.0/94-15 H12, H15, 15.0/96-15 H12, H15, D12A,

**Fronts:** 85/8.0-15 D12, D15, D20. Cars not running the correct tire will be penalized to last in that event.

**\*Until further notice 2024 Right Rear Tire rule: New tires will be marked in time trials only. Approved used tires may be run anytime during the event if they are stamped by Knoxville Officials before Hot Laps each night at the tech area.**

### **3.1-360 CYLINDER HEADS**

1. List of Cylinder Heads approved for ASCS competition is as follows:
  - A. Chevy - #27-211
  - B. Ford- #27-223
  - C. Mopar- #27-222
2. Spec Heads: Brodix Chevrolet Style Heads part # 27-211 with ASCS stamp. During polishing, the edges of the letters on the ASCS logos are sometimes inadvertently brushed with the polish wheel. This is permissible as long as letters are still intact. Angle milling is allowed if the head remains within 1 degree of original manufacturer's specifications. Excessive porting and/or angle milling of the ASCS logo Cylinder Heads may affect their structural integrity and is in no way recommended by Brodix.
3. Spec Heads: Brodix Ford Style Heads part # 27-223 with ASCS stamp. Intake opening must be 2.150 inches tall by 1.300 inches wide. During polishing, the edges of the letters on the ASCS logos are sometimes inadvertently brushed with the polish wheel. This is permissible if letters are still intact. Angle milling is allowed as long as the head remains within 1 degree of original manufacturer's specifications. Excessive porting and/or angle milling of the ASCS logo Cylinder Heads may affect their structural integrity and is in no way recommended by Brodix.
4. Spec Heads: Brodix Mopar Style Heads part # 27-222 with ASCS stamp. During polishing, the edges of the letters on the ASCS logos are sometimes inadvertently brushed with the polish wheel. This is permissible as long as letters are still intact. Angle milling is allowed if the head remains within 1 degree of original manufacturer's specifications. Excessive porting and/or angle milling of the ASCS logo Cylinder Heads may affect their structural integrity and is in no way recommended by Brodix.
5. Valve angle and placement may not be altered in any way on the Brodix ASCS logo heads. **No welding of any kind, internally or externally, is allowed.** Checking fixtures may be used to check head dimensions.

#### **3.2-Guidelines regarding porting and polishing:**

##### **Intake port openings must match the following:**

- A. ASCS Chevy- FP #1206 or equivalent
- B. Ford- FP#1262 or equivalent
- C. Mopar- FP#1213 or equivalent
- Porting and polishing of intake ports is allowed with the following restrictions:
  - A. All ASCS logos must remain completely intact.
  - B. **\*\*Intake port openings must meet previous requirements and checking fixtures currently used.**
  - C. Valve spring pockets may not be welded or altered in any way with intent to relocate ports.
  - D. Maximum allowable width of pushrod area as follows:

1. ASCS Chevy- 2.630
2. ASCS Ford- 1.300
3. ASCS Mopar-2.450

*\*\*\*Width of the intake runner at the pushrod area will be measured on the outside of the intake ports, at the location of the original pushrod machining from the original manufacturer. This area will be measured with an approved gauge. \*\*\**

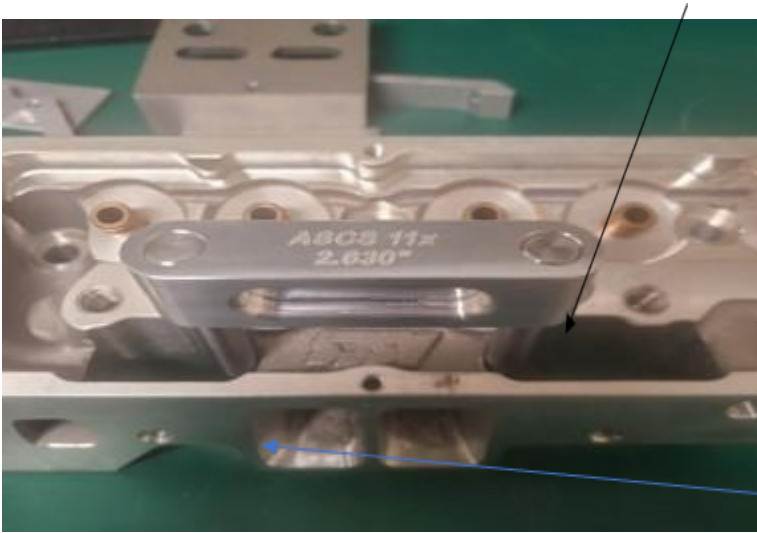

existing rule.

**\*\*Intake port openings must meet**

1. Absolutely no exhaust port relocation, raising, enlargement, or reshaping of any kind.
  - A. Polishing is allowed if the original ASCS logo is not affected, or port shape is not altered substantially.
  - B. Valve spring pockets may not be welded or altered in any way with intent to relocate parts.
  - C. Exhaust port openings must meet previous requirements and checking fixtures currently utilized by sanctioned ASCS tracks.
2. Polishing will be allowed in the combustion chamber area to avoid hot spot chaffing.

**3.3-Any internally repaired ASCS spec head must be re-certified by Brodix.**

1. All spec heads must remain within 1 degree of the original manufacturing [Chevy: 23 degree, Ford 20 degree, Mopar 18 degree]
2. Penalty for altered spec head will be subject to suspension, for one calendar year. Forfeit all points and money won, during the race which the infraction was found, and subject to a \$500 fine that must be paid to Knoxville Raceway before reinstatement.
3. All oil pans must have an inspection plug, pans without plug will be subject to pan removal at any time.

4. No Turbos or blowers.
5. Only two valves and one spark plug per cylinder allowed. No big blocks.
6. No computer operated or controlled parts, such as fuel injections, traction control, fuel systems, crank trigger switches in the cockpit, chassis adjusting systems, shocks, etc.
7. No offset motors will be allowed, engines must be directly in front of driver. Driver must straddle driveline.

### **3.4-3.12 INTENTIONALLY LEFT BLANK**

#### **3.13-FUEL INJECTION**

- A. Fuel injection will have a maximum stack bore of 2 3/16" of at least 3 inches. If sleeved down; sleeve must be at least three inches long and measure 2 3/16" throughout.
- B. One fuel nozzle per cylinder. Stacks and runners must be independent from each other from the top of the stack to the valve. Butterfly and shaft model injectors only, no side plate or rotary barrels allowed.
- C. No electronic injection.

#### **3.14-SHOCKS**

- A. No cockpit adjustable shocks.
- B. No electronically adjustable shocks.

#### **3.15-Engine *TECH Procedures***

- A. Selected Engines will be cubic inch checked by decision of Competition Director.
- B. Stack size and Push Rod location check, also at the discretion of the Competition Director, rod checks, fuel and any other areas the track may request.
- C. Intake and if needed exhaust port logo check,

#### **3.16-360 CLASS WINGS**

- A. ASCS wings are allowed with 8 degree side panels. Cock pit adjustable wing sliders are allowed.
- B. Center Foil maximum size of 25 square feet with a maximum width of 60 inches with a one degree plus or minus tolerance.
- C. Center Foil shall be fully sheathed in aluminum. Vent holes are strictly prohibited.

**D. Maximum 2" removable wicker bill/ Flat Wings Only** may be mounted on the rear edge of the center foil. Knoxville weekly shows only, other sanctions may or may not allow a 2 inch wicker bill. Wicker bill must be 90 degrees to the top of the Center Foil. No built-in wicker bills or gurney lips allowed.

**E.** Other than the slider mechanism, no moving parts allowed on or in foil structure.

**F.** The 12-inch section located at the rear of the Center Foil must not have the belly/curl arc out of proportion with the rest of the Center Foil. The belly/curl arc must span the entire length of the Center Foil and appear to be a gradual arc with the deepest point no further back than 48 inches from the leading edge. As measured on a 12-inch straight edge, the belly at 6 inches from the rear of the Foil may not be deeper than ½ inch. There is zero tolerance on this ½ inch depth. It is suggested that the wing blueprint specify 15/32-inch depth, so that if any deflection or movement of the wing occurs, the depth will not exceed the ½ inch specification. (This ½ inch measurement ensures that the belly/curl arc is gradual.)

**G.** Intentionally left blank

**H.** The belly/curl arc must start at the radius of the Center Foil's leading edge and shall not exceed a depth of 2½ inches. Center Foil thickness cannot exceed 9 inches. Center Foil top surface from side to side must remain flat. Center Foil must be one-piece construction. No split or bi wings will be permitted. Wings must be fabricated of metal alloys only. No fiberglass, carbon fiber or other similar material may be used in the basic framework of the wings. Top wing must not extend beyond outside of rear tires.

**I.** Two stationary foils or rudders will be allowed to run the entire length of the underneath portion of the top wing. Maximum height proportions are 1 inch at the front and 3 inches at the rear. Nowhere shall the foil exceed 3 inches in height. The top wing can be cockpit/driver adjustable.

**4.0- Wing Posts\***, see section 7.22

## **5.0- PRO Sprints**

**5.1 Weight Rule** – 1500 lbs. with the driver after a race.

**5.2** Tubing and nerf bars must be hollow. This rule is in effect for all events.

**5.3** For bolt on weights **and rules please refer to 410 rules as to mounting.**

**5.4/5.5** Intentionally *Left Blank*

**5.6-PRO Sprint Spec ENGINE\*\***

## **5.7-Sealed Engine:**

- A)** Sealed Engine package part # GMP-CT525-KX will be specified as the only engine for use within the Knoxville Raceway PRO Sprint division.
- B)** Only Approved Vendors may provide this Sealed Engine package option.
- C)** This Sealed Engine Package Utilizes Mandated Bolt on Components... The Engine and All Mandated Bolt on Components Must Remain in their Original Configuration and Form as Purchased and Delivered from the approved vendors.
- D)** This Engine retains all GM factory installed Seals and includes Vendor provided Performance Serial Numbered Cable Seals with QR coded Seals to allow tracking on the Intake Manifold, Valve Covers, Front Timing Cover and Oil Pan.
- E)** This Sealed Engine must remain intact and Not Tampered with. Any Seals that have been Removed or Tampered with will make the Engine non-conforming and Not Eligible for Competition at Knoxville Raceway. The Penalty for Anyone Tampering with Seals, modifying any Integral Components within the Seals will be Subject to Expulsion from Participating at Knoxville Raceway as a Driver or Owner for 365 days from the date of Expulsion and Fined \$1000.00 to be paid prior to Returning to Competition. The Penalty for anyone Tampering with or Modifying any External Components Outside the Seals Including Ignition Control Box is Subject to a Two Week Suspension and Fined \$250.00 to be paid prior to returning to Competition.
- F)** Carburetor: Spec Holley 80535-2. The only Allowed Changes are Jetting, Power Valves, and Air Bleeds. No other Modifications are allowed. Carburetor will be subject to Go no Go Gauge Checking as part of Tech.
- G)** Carburetor Restrictor/Spacer: Each Restrictor/Spacer is Serial Numbered to each Engine and will also be subject to- Go no- Go Gauge Checking as part of Tech.
- H)** Engine Information Contact: Karl's Performance 855-806-1147

**5.8- Tire Rule-** Same as Knoxville 360 and 410's any legal 16" RR tire and LR Tires as listed above. Cars not running legal tires will be penalized to last place in that event.

## **5.9- Intentionally Left Blank**

**5.10 - Wing Rule** - Maximum top wing size of 25 square feet, with maximum of 30-inch by 72-inch side panels.

**5.11** Side panels must be one piece.

**5.12** No split wings or bi-wings.

**5.13** Top wings must not extend beyond outside of rear tires.

**5.14** No turn-up/wicker bill allowed, except on flat wings. 1" maximum

**5.15** Maximum front wing size to be six square feet total with a maximum width of 36 inches and 12-inch side panels.

**5.16** No foils or rudders over 3" will be allowed.

**5.17** No side foils, rudders or panels are to extend beyond roll cage on any side, no body pieces to extend beyond or underneath front torsion tube except hood. Sunshields cannot restrict vision.

**5.18** \* No wedges or foils underneath race car. No pieces may be added to the frame so as to resemble, imitate, or be specifically designed to deflect, trap or form a wind break/air foil of any nature, except those used to cool/protect the motor & braking system. \*Cockpit adjustable Top wing sliders are allowed.

**5.19- Wing Posts**, see section 7.22

**5.20- Intentionally left blank**

**6.0-Intentionally left blank**

## **7.00-Knoxville Raceway Safety and Technical Inspection Rules**

### **7.1-Fire Suppression System(s)\*\***

**These systems are mandatory for all races at Knoxville Raceway.**

1. A fire suppression system that meets the SFI 17.3 specification must be installed and functional.
2. The fire suppression system must include a thermal trigger and a manual trigger, both mounted in the driver's compartment. The thermal trigger must be in the lower area of the drivers compartment forward of the seat near the area of the fuel pump. The manual trigger must be mounted within reach of the driver on the forward left-hand side of the cockpit. A minimum of one nozzle must be mounted in the lower area of the cockpit forward of the seat.
3. The DOT approved cylinder manufactured of aluminum or steel must be securely mounted to the frame per the manufacturer's instructions and the discretion of track Officials. The cylinder must have a minimum capacity of 5 lbs.



4. The system must be fully charged and display a legible and valid SFI 17.3 and manufacture label, easily viewable at any time by Track Officials. Cylinders that are beyond useful certification date must be inspected, serviced and re-labeled by the manufacturer.

5. If a nozzle is connected to the cylinder with a line, the line must be steel or steel reinforced and must be triggered at the end of the line.

#### Approved Manufacturers

- Lifeline Fire & Safety USA, 540-251-2724
- Safety Systems Inc. (Firebottle), Ft Myers, FL, 239-995-6300
- Spa Technique Inc. Indianapolis, IN 317-271-7941
- Safecraft Safety Equipment, Martinez, CA, 800-400-2259

### **7.2- Electronics, Gauges and Dashes\*\***

1. 2-way communication devices in or attached to the race vehicle or on the driver's person will not be permitted.
2. Cellular, satellite and/or Wi-Fi devices in or attached to the race vehicle or the driver's person will not be permitted (including cell phones or smart watches).
3. Antennas will not be permitted in or attached to the race vehicle or carried by the driver.
4. All forms of a vehicle position system (GPS) will not be permitted.
5. Only approved lap timing and or lap time recording devices (transponders) will be permitted.
6. Gauges to monitor engine conditions are permitted at the discretion of Knoxville
7. Raceway Officials.
8. All Electric gages whether analog or digital, except tachometers, will only be permitted to have one (1) input from the respective gauge sensor. Outputs from the gauges will not be permitted. Tachometers will be permitted to record engine RPM for recall.
9. Electronic Dash Modules will not be allowed.
10. All additional wiring harnesses related to electronic dash modules, or any other type of data acquisition must be completely removed from the race vehicle during an event.

**7.3- BOLTS\*\***-No hollow or drilled out bolts anywhere.

**7.4-SHOCKS\*\***- No cockpit adjustable shocks. No Electronically adjustable shocks. Only one shock per corner (4) on a car. Only conventional and thru-rod style shock absorbers will be allowed. Currently the only approved thru-rod style shocks:

- Penske PS-7700T

**7.5-TORSION BAR\*\***- adjustments from the cockpit are not allowed. Torsion bars stop and arm locks are required on both front bars. No additional components will be added to the torsion arm or other suspension components to help control the suspension, such as, but not limited to additional shocks, springs, spring arms, etc.. Any new suspension configuration or new style shock configuration must be approved by Knoxville Raceway Officials prior to being placed into competition. Performance, safety, cost, along with other variables, will factor into the approval process. It is recommended that the approval process be completed prior to product production.

**7.6-TORSION ARM STOPS\*\***-All cars shall be equipped with a torsion bar stop retainer system on both sides of the front torsion bar. Retainer may be rod type with a securing cap or insert with expanding mandrel.

**Current approved kits:**

1. Moose Block 1200 Retainer Kit
2. All Star Performance All Star 10730 Retainer
3. Maring Safety Retainer
4. Butlerbuilt Mandrel
5. KKR grove and clip
6. Kaeding Clip
7. DMI – T-REX (Torsion Restraint Express System
- \*8. Schroeder Part Number: “BARS” (for Schroeder bars with relief in ends) Schroeder Part Number: “RWLAR” (Wedge Lock)

**7.7-BATTERIES and RADIOS\*\*** No batteries, other than those included in communications devices (RaceCeivers) required by Knoxville Raceway, or in specific non magneto equipped engines. RaceCeivers or other approved one way communication radios with Officials only are required. Radios must be in working condition and turned on. Failure to do so may result in two position penalties or disqualification

**7.8-NUMBERS\*\*** – Those must be visible and neat in appearance. Numbers must be on both the left and right side of the tail as well as the side panels of the top wing. Wing letter minimum sizes, numbers must be at least 18 inches high and letters at least 12 inches high.

### **7.9-MUFFLERS/HEADERS\*\***

- A. Only the 14 inch Flowmaster (part #53545-10) and the Schoenfeld (part # 14272735-78) mufflers will be permitted unless otherwise notified in writing prior to any event. The specified mufflers must remain unaltered from the manufacturer.
- B. Titanium, carbon fiber and/or any other type of exotic material mufflers will not be permitted.
- C. All mufflers must be securely mounted. Mufflers that are mounted with pop rivets and/or sheet metal screws will not be permitted.
- D. Any header/muffler changes after going through inspection will need to be reinspected by raceway officials.
- E. Any muffler and or header that have been altered will not be permitted. Altering mufflers will result in loss of points and all money for the night's event. Only one muffler per header allowed. Mufflers must be welded or attached by approved clamps. Loss of mufflers not properly attached will result in disqualification to the rear of that event. Mufflers may not exceed the maximum decibel (DBA) reading on the tracks DBA meter.
- F. When qualifying, any car determined to be more than the Decibel limit(s) set by either the track and/or any local agency, will receive only one (1) lap of qualifying at the end of time trials and the highest qualifying position the car may achieve is the first position behind the invert. If the car pulls off and no time is recorded, the car will be permitted one (1) lap at the end of time trials. If during that attempt the car remains louder than the limit it will result in disqualification.

**7.10-BRAKES\*\***- Only steel, aluminum, titanium, or carbon fiber brake rotors allowed. Cars may not race without working brakes.

**7.11-WHEELS and wheel covers\*\*** Maximum right rear width is 18 inches and maximum left rear width is 15 inches. Aluminum wheels only.

**Wheel covers: it is highly recommended that wheel covers have a minimum of 5 mounting points. However, both 5 and 3 mounting point wheel covers will be allowed for competition under the following conditions: Wheel covers having a minimum of 5 attachment points may continue to use dzus fasteners. Fasteners must be made of steel only. Wheel covers having only 3 attachment points must be bolted-on at all 3 points utilizing a minimum 5/16", flanged steel bolt and an approved fastening (nut assembly) system. (Titanium fasteners are allowed.) Rounded or flat topped Allen/Screwdriver/ headed bolts with washers are recommended.**

Approved fastening (nut assembly) systems: Keyser Manufacturing, part #100 7-101.

Wehrs Manufacturing Part # (WM377A-312 Aluminum 5/16) (WM377S-312 Steel 5/16)

Triple X Chassis Part # SC-WH-7810(for a 1" spring) / SC-WH-7820(for a 1 3/8" spring)

Smith Precision Products Part # MC-516-18 Speedway Motors part # 910-07119)

Optional fastening systems that are equal or superior to the above approved system will be approved at the sole discretion of Knoxville Raceway Officials.

**7.12-TIRES\*\*** Tire rules are in effect for all classes. Cars may not race with a flat tire on the right rear, left rear or right front. Wheel rims on the sidewall against the track are considered flat. Left front tires that are off the bead will be sent to the work area.

Digital air bleeders are allowed but cannot be remotely controlled.

**7.13-BUMPERS & NERF BARS\*\*** All rear bumpers must be steel, no titanium, no tungsten, minimum one inch in diameter, minimum .065 thick. All Tubing must be hollow. This rule is in effect for all events. A bumpers, nerf bars etc. must be bolted on.

The front bumper must not extend past the more than eight (8) inches from the frame and/or the measurement from the center of the front axle to the front of bumper must not exceed 23 ½ inches. Left and right nerf bars must attach to the chassis in three (3) points. Minimum 1.00 "diameter and .065" material thickness. If you lose a rear bumper, you may continue the race unless the car is stopped. If a red occurs, you must repair or replace the bumper in the allotted time before you can restart.

**7.14 -FRONT AXLES\*\*** Magnetic steel only.

**Minimum front axle size:** Tubing must be hollow. This rule is in effect for all events.

**\*Knoxville weekly shows allowed, other series rules may apply at those races**

2 1/2" diameter x 0.095" wall and thicker

2 3/8" diameter x 0.095" wall and thicker

\*2 1/4" diameter x 0.120" wall and thicker

\*2" diameter x 0.156" wall and thicker

**7.15-TETHERS\*\* - Approved tethers are required** King Pin Tethers are mandatory in all classes. All axle tethers should connect around the axle either by clamp, intermittent rosette welded ring, or tether. Tethers terminating on the shock tower are for emergency use and should not be considered a satisfactory mounting point. Tethers should also be mounted around the front engine motor mount upright, not the radiator upright. Approved front axle tether systems are mandatory. The tether mounting must meet the SFI 55.1 specification which includes two (2) Vectran® HS V-12, or Dynemma 12 tethers attached to the chassis. Tether systems must include a "king pin to king pin" tether that will attach to the axle clamp/band. Tether cables should be installed using the manufacturer's provided fasteners. Tether systems of any type must be pre-approved and installed in accordance with the manufacturer's instructions. No "bolt to bolt" radius rod axle tethers will be allowed.

All axle tether systems must clamp to or wrap around the axle per the manufacturer's instructions.

Current approved:

**Butlerbuilt:**

- A. **BBP 4922-225** 2 1/4" Axle diameter complete kit
- B. **BBP 4922-238** 2 3/8" Axle diameter complete kit
- C. **BBP 4922-250** 2 1/2" Axle diameter complete kit
- D. **BBP-4924 King Pin Tether**

**C & R Racing Sprint Car Front Axle King Pin Tether System**

- E. Radius Rod Tethers part Numbers (NOT ALLOWED IN 2020 unless utilizing an axle clamp or other approved axle mounting system.)
- F. CRA-102-255/265/27/275/28-A
- G. CRA – 103 – 53 – A
- H. CRA – 103 – 54 – A
- I. CRA – 103 – 55 – A

**Amick Associates Radius Rod Axle Tether**

- A. Part Number: WC-101M 8mm X 36" Radius Rod Tether  
(15,000 lbs. Nominal Breaking Strength) (V-12 with Red Tracer)

The approved tethers may be revised from time-to-time with additional approvals and/or other changes to the approved list.

**7.16** – Intentionally Left Blank

**7.17-HOODS\***

- A. All cars will be required to run a full sprint appearing hood.
- B. Hood must extend to the front torsion tubes or a similar location on coil-over cars.
- C. While the hood may be a multiple piece design it must appear to be one continuous piece.
- D. Hoods and nose pieces may not extend above the frame and or roll cage to create any additional aero effects. Air induction areas of the hood may be subject to inspection regarding aero effects. Wedges and/or foils underneath the racecar will not be permitted.

**7.18-BODY SIDE PANEL\*\***

**\*A.** Panel opening on the right side must have minimum opening of 10" by 21". Maximum distance from frame is 7". **\*Left side panel Opening:**

**B.** Radius rod protectors will be permitted. The maximum protector vertical opening will be 10 inches in height by 24 inches long and it must not extend more than 3 ½ inches from the outside edge of the bottom frame rails.

**C.** A maximum 1 ½ inch wide by 20 inch long exhaust fume deflector, located on the bottom side-body panel at the rear edge will be permitted. The turnout angle must not exceed 90 degrees.

**D.** Elbow room alterations must be limited to the area between the roll cage and not be designed to trap or deflect air to gain a competitive advantage.

**F.** We suggest that any side panel configurations beyond the normal appearance be pre-approved by Knoxville Raceway Officials. All other side paneling must be fabricated flat and must not extend past the outside edge of the frame rails more than the thickness of the paneling material.

**G.** With the addition of the new roll cage support bars referenced in Section 1.1A of the 2019 Sprint Car Rules the following adjustment to Section 7.18 shall take effect immediately. The right side minimum panel opening dimension of 21" x 10" shall stay in effect. \*The left side paneling may extend to but not forward of the support bar. The use of a left side arm guard as part of the paneling is acceptable as long as it or any other part of the paneling does not prevent left-side driver entry or exit at the discretion of track Officials.

**7.19-DRAG LINKS, TIE RODS & RADIUS RODS (LF)\*\*** –Drag links must utilize an approved tether fastened to the frame. Captured steel heim ends and 1" diameter steel construction with .058 sidewalls is required for drag links and tie rods. Steel heim ends are required on steering linkage and steel left front radius rod. Left Front Radius rod shall be no less than .058" thickness steel tubing. Tubing and nerf bars must be hollow. This rule is in effect for all events.

**7.20 -FLOOR PAN\*\***– Steel or aluminum only. Wedges and/or foils underneath the racecar will not be permitted.

**7.21- CARBON FIBER\*\*** Excluding brake rotors, torque tubes, no carbon fiber parts allowed in the suspension, steering components, or drive line, including radius rods, no carbon fiber engine sleeves, carbon fiber manifolds and/or any other injection type pieces manufactured from carbon fiber. Carbon fiber injection stacks are allowed. See 7.28 Seats for approved carbon fiber seats.

**7.22- Wing Posts\*\*** Wing T-Post will be built from 1" X .083" minimum ASTM4130 normalized steel or equivalent material.

Wing attachment designs will be subject to approval. The only cast pieces approved will be HRP Part #HRP8811-A75-HD. If new T-Post designs are developed, they must be submitted for approval.

### **\*7.23-Traction Control Devices\*\***

- A. Traction control devices of any type are not permitted at any time, during any event.
- B. Any team found with a traction control device in pre and/or post-race inspection shall be disqualified from that event. Additional penalties, including indefinite suspension and/or fines, and/or any penalty deemed appropriate by Knoxville Raceway Officials. From time-to-time random inspections will occur and various components may be impounded for further analysis and inspection including, but not limited to ignition systems, \*ignition boxes, wiring looms and/or tachometers.

### **7.24-DRIVELINE SYSTEMS\*\***

- A. All cars must utilize either a driveline strap or and a **driveline hoop (Highly recommended)** restraint constructed of .065 steel either welded or bolted to the chassis. Metal hoop restraints must react positive to magnet testing. Driveline Blocks are also allowed and recommended.
- B. The rear cross member must be constructed of 1" x .083 or 1 ¼ " x .065. The rear cross member or rear end bar should be mounted below the lowest part of the seat. Additional material should be added to the seat crossbar for added protection.
- D. Tethers should be considered in this area if additional room for steel protection is not available. Driveline U-Joint scatter shields, steel torque ball housings, minimum .120 thick and or torque ball U-Joint containment blankets are required. Driveline blocks are strongly suggested.
- E. New products are being developed for added protection in these areas. We will be updating these rules for driveline restraint systems.

### **7.25-SEATBELTS\*\***

- A. Each car will be equipped with minimum SFI 16.1 or SFI 16.5 approved restraint system, belts must be replaced two years after the date of manufacture. The belts must be relaced by the expiration date as stated on the belts by the manufacturer.
- B. Seat belt restraint systems shall be installed and used in accordance with manufacturer's instructions. In any type of manufacturer's installation, the fasteners must be magnetic steel unless using type of mount in which the seat belt wraps around the roll cage.
- C. Seat belt material should not be permitted to contact any sharp or metal edge, including where the material passes through the seat.

**D.** In any type of manufacturer's installation, the fasteners must be as supplied by the manufacturer. **The seat belts must be mounted to the chassis per the manufacturer's instructions. No belts to seat installation will be allowed.**

#### **7.26-DRIVER'S EQUIPMENT\*\***

**A.** The driver's suit should be constructed of multi-layered fire retardant material. (SFI 3.2A/5 label) Knoxville Raceway reserves the right to reject any driver's suit it deems unsafe. Nomex underwear and socks (SFI 3.3) are suggested. A head sock is also suggested. Driving gloves and racing shoes (SFI 3.3) are strongly suggested.

**B.** Knoxville Raceway reserves the right to inspect any helmet for cracks or structural damage and reject same if necessary. \* All drivers must wear a full-face helmet with a minimum safety rating of FIA 8859-2015, FIA 8860-2018, Snell SA2020, Snell EA2016, Snell SA2015. **\*(FIA and Snell dates may be updated in these rules at a later date). Five years from date of purchase should be a guideline for drivers to use as a replacement time frame.** It is strongly recommended that helmets should have the Eject™ helmet removal system installed as per the manufacturer's instructions.

**C.** At all times during an event, including practice, qualifying and competition (excluding starting the car for engine warm-up) drivers must wear an SFI-approved head and neck restraint device/system that is properly mounted and connected per the manufacturer's instructions. The device should meet SFI 38.1 specifications and display a valid SFI 38.1 label. The head and neck restraint must be SFI 38.1 approved and display a legible and valid \*SFI 38.1 label. \*Approved systems subject to change.

**C.2** Arm restraints are recommended and must be connected and used as instructed by the manufacturer.

#### **7.27-CAR'S EQUIPMENT\*\***

**A.** Use a securely fastened steering wheel with a quick disconnect for easy removal.

**B.** All roll cages must be higher than the driver's helmet.

**\*C.** Opening on the left-hand side of cockpit must be a minimum of 14 inches. The body work on the right side must maintain the current 10" x 21" opening.

**D.** Head and neck restraint systems are required. These systems should be properly mounted and connected according to the manufacturer's instructions. The device should meet SFI 3.3 specifications and display a valid SFI 3.1-3.3 label. \*Approved systems subject to change.

**E.** No pop rivets or cotter keys to be used to fasten wings, bumpers or nerf bars to race car. Fasteners must be used in all mounting locations.



**F.** You cannot race without a hood. Any damaged hood must be repaired to the Officials requirements to go back into competition.

**G.** Intentionally left blank.

**H.** No mirrors of any kind. A rock screen is strongly suggested.

**I.** Engines, fuel, tires, and mufflers may be inspected at any time. Fuel will be inspected during periodic intervals. Officials may at their discretion inspect any car entered for competition in any racing event at any time. Officials may impound a part/component, engine and/or any other components and/or the complete car for analysis.

**J.** The only chassis and/or frame adjustable device, including adjustable shock absorbers that may be within the driver's reach will be one (1) top wing adjuster, for the top-wing slider mechanism. The slider must be one dimensional and allow forward and rearward movement only. In-cockpit fuel shut off valves should be clearly marked as to on and off position.

#### **7.28-SEATS\*\***

**a.** All current seats must be full containment type constructed of aluminum or approved carbon fiber and must adhere to the general design specifications of SFI 39.2 seat construction standards. The design shall include a comprehensive head surround, shoulder and torso support system, energy impact foam, and removable head foam.

**b.** Carbon fiber seats must have a current valid SFI 39.2 certification.

**c.** Up fitting a current seat with bolt-on kits will be permitted with a seat manufacturer-produced kit and an acceptable base seat approved by the seat manufacturer. Components must include a comprehensive head surround, shoulder and torso support system, energy impact foam. Must be installed in accordance with seat manufacturer's instructions. Combining components may not meet SFI 39.2 Certification.

**d.** Seats must be used as supplied and installed following instructions provided by the seat manufacturer.

**e.** If the left-side head surround is 7"-inches or less when measured from the back of the headrest, then a left-side head net meeting the SFI 37.1 must be installed with a quick-release latch. A minimum left side head surround of 4"-inches is required.

**f.** The rear cross member or rear end bar should be mounted below the lowest part of the seat. Additional material should be added to the seat crossbar for added extra protection.

**\*8.0-** Intentionally left Blank

## 9.0-SPORTSMANSHIP\*\*

Sprint car racing is a very emotional sport. Therefore, good sportsmanship is the cornerstone of any competitive racing program. This must include respect for all participants, drivers, owners, pit crews, and officials. For our part we will try to be consistent with our decisions, no matter what or who is involved. We will treat all participants with respect and expect similar treatment in return. Fighting, harassment, or verbally abusing any officials, security, safety workers, firemen, tow truck operators, push truck operators etc., will not be tolerated. Drivers, remember that you are responsible for the actions of your crews. Being in the other competitors' pit area or tech area without a car present for tech or scales is considered already at fault. Any driver who exits their car and approaches another driver/car while under yellow may be subject to a fine of \$1,000 to \$2,000, and/or be suspended for two race weekends. The team will also forfeit all winnings and points for the night. To curtail the incidents at Knoxville Raceway, the following system of penalties will be in force:

1. Threatening or obscene gestures aimed at an official or a competitor \$100.00 to \$1000.00.
2. Foul language directed at an official or a competitor \$100 to \$1000.00.
3. Rough driving \$100 to \$500, unapproved push offs onto raceway, \$100.00 to \$500.00.
4. Fighting in pits \$200 to \$2000.00.
5. Pushing, shoving, or assaulting an official \$500 to \$2000.00.
6. Disqualification may be an additional penalty in the case of flagrant violations. Disqualifications will be for a specific number of race nights. Rain outs will not be included when a penalty involves a specific number of races. Probation periods may also be utilized.
7. Sportsmanship does not just pertain to activities at the track. As a Competitor at Knoxville Raceway, you are expected to always act professionally. For that reason, the same principles and guidelines found in this Rule Book apply to **your activities online**. Ultimately, you are solely responsible for what you post online. Before creating online content, consider some of the risks and rewards that are involved. Keep in mind that any of your conduct that adversely affects Knoxville Raceway, Knoxville Raceway Officials, and or other competitors, may result in disciplinary action up to and including suspension and fines up to \$2,000.00. These rules also pertain to Knoxville Raceway Officials and employees as well.
8. **By participating at Knoxville Raceway, all participants are signifying that they agree to comply with these rules and regulations.**

**9.1-Appeal of Fines** Fines and or disqualifications and probation periods will be at the discretion of the Race Director. You may appeal your case to the Race Committee of the Marion County Fair Association. All fines must be paid before you can return to participation at Knoxville Raceway.

**9.2-Penalties for infractions:** Any car, team or driver not meeting Knoxville Raceway safety standards and procedures is subject to automatic disqualification and or fines. Penalties may range from \$50.00 to \$2,000.00. Points may also be deducted from the night's finish. Last place money and points may or may not be awarded at the discretion of the Race Director. Suspensions will be determined.

**9.3-Technical Inspection** – Knoxville Raceway reserves the right to inspect any part of any race car at its discretion. Any team refusing inspections at any time during or after an event will be disqualified, with all points and money won forfeited. Fines from \$50.00 to \$2000.00 may be implemented.

A. Engines, chassis, suspension, ignition/electrical, tires, fuel and/or sound/mufflers may be inspected at any time.

B. Fuel testing performed at the track; further testing will be paid for by the competitor if needed.

C. Officials may at their discretion, impound a part/component, engine and/or any other components and/or the complete car for competitive, and/or research data analysis.

D. Officials may at their discretion inspect any car entered for competition in any racing event at any time.

**10.0 - Safety and Inspections** Knoxville Raceway Officials shall have full responsibility for safety rules and regulations enforcement at all events. At the discretion of the Race Director, and or Competition Director, any competitor may be disqualified for rule violations or hazardous equipment or hazardous actions. All race cars are subject to be inspected at any time. If a part is deemed non-conforming, responsibility for proving otherwise rests with the team being checked.

**10.1**-Inspecting and affixing stickers to the vehicle and or parts of the vehicle by the inspector(s) shall mean only that the vehicle or parts is approved for participation in a competitive event shall not be construed in any way that the said parts are considered in any way guaranteed mechanically sound. Be it further declared that the inspector(s) shall not be liable, for any mechanical failures, nor for any losses or injuries resulting from the inspections.

**11.0-SCALING PROCEDURES\*\*:** Additional weight will be permitted but must be mounted and fastened to the frame and/or chassis in a secure manner. All additional weight must be mounted and fastened in the area between the bottom frame rails and axles but mounted no higher than the upper rails. The addition of additional weight during and yellow and/or red flag condition will not be permitted. **All additional weight must be painted white and have the car number on it in black numbers.**

**11.1** The scales will be available and open to scale cars prior to hot laps at every event.

**11.2** All cars will be scaled/weighed during qualifying and the top five cars will be weighed after A feature events. Drivers will be instructed over the radio if the scales are open for other feature events. 410 class minimum weight 1425lbs/with driver, 360 class 1500lbs/with driver, PRO Series 1500lbs /with driver. Additional cars may be weighed at any time after any event.

**11.3** If a car fails to meet the minimum weight restriction, or other scale violations the following penalties apply.

1. **Time Trials:** The car is scored last in time trials.
2. **Heat Race:** Car is disqualified from that event but remains eligible for the B Main starting last.
3. **Final Qualifying Mains and or other races:** Car is scored last.

4. **A Main:** Car is scored last.

**11.4** - Intentionally Left Blank

**11.5** - Intentionally Left Blank

**11.6** Cars must proceed immediately to the scale /tech area. Crew members and or other race team personnel will not be permitted in the scale/tech area and or to approach the car prior to reaching the designated area until it is weighed and released.

**11.7** All drivers must remain seated in their typical racing position in the vehicle during the scaling process unless released by Officials. If a driver leaves the car without prior consent it could result in a disqualification from the event in which the car is competing in.

**12.0-** Intentionally left blank

**13.0-** Intentionally Left Blank

**14.0- Protests\*\*:**

**14.1** All protests must be turned into the Competition Director in writing within Ten (10) minutes of the end of the race. The protest fee must be paid in cash at the time of the protest. Only the car owner, or the driver may turn in an official protest. Only teams competing in the current Knoxville point season and in the top 20 in points may file a protest. Any refusal of inspection and/or non-compliance during an official protest will result in the disqualification of the protested car and the prescribed penalties. Protests may only be made by teams competing in the event.

**14.2** Any one team will be limited to a maximum of Two (2) protests in a season.

**14.3** If the car protested is found to be nonconforming, the protesting fees will be returned to the team filing the protest less the filing fee and any lab costs.  
If the car protested is found legal, the protesting fees will be released to the protested team less the protest filing fee and any lab costs.

**14.4** Any altercation relating to the incident with Officials and/or any other racing participants by the team filing the protest will nullify the objection.

**14.5** Knoxville Raceway Officials reserves the right to ask for a conformance test at any time (sealed motor and/or otherwise). If through testing procedures a car is found to be nonconforming, responsibility for proving otherwise is solely with the team that was checked. There will be no exchange of money for tests asked for by officials when a formal protest is not turned in.

**14.6** Knoxville Raceway Officials reserves the right to accept or deny any protest based on their sole discretion. 'Grudge' protests and/or any protest that are 'not in the spirit of good standing will be denied. No protests will be accepted on judgment decisions.

**14.7** In the event a car is protested and found to be illegal, the driver and car protested shall have all points and money forfeited that were won during the race program in question and may be suspended. Tire protest have different penalties.

**14.8 Protest Fees (Figures in Parenthesis Are Filing Fees)**

1. Engine (heads, intake and or pan off) \$2000.00 (\$100)
2. Fuel test \$200 lab tests extra
3. \*Other technical protest: \$500 to \$2,000.00 (\$100)

**Fines/Penalties:** see 9.1, 9.2

**\*15.00-\*TIRE PROTESTS\*\*:**

**\*15.1** Tire protests may involve one and/or both rear tires or front tires, or any tire in the pit or hauler. The fee will be \$400.00 per tire collected by the track. The \$400.00 dollar protest fee will not be refunded. The protest will require the submission of the tire for samples taken by Knoxville Raceway Officials from the car (car owner, driver and/or designated representative) which has been protested. The tire will be confiscated. The tire(s) or (samples) involved in the protest will be shipped, processed, and chemically analyzed at a facility designated by Knoxville Raceway and/or the tire manufacturer. The determination of the facility will be final and non-appealable. Tires found to be legal will be returned.

**15.2 TIRE Prepping PENALTIES All Classes\*\***

1st offense, Disqualified, loss of nights points and purse.

\$2000.00 fine payable to the Knoxville Raceway Charitable Organization (KRCO). Payable by driver or owner.

\$400.00 Tire testing refund pd to Knoxville Raceway, paid by driver or owner.

Suspensions, To be determined including driver and owner.

2nd offense, Suspensions and fines to be determined including driver and owner.

3<sup>rd</sup> offense, Suspensions and fines to be determined including driver and owner.

All decisions regarding tire prep penalties will be issued after a lab test has been performed by a certified Laboratory. Tires not conforming to Hoosier Benchmark properties will be considered altered.

\*Tire Testing Procedures: Tire tests will be sent to certified lab of tracks choice. Tire samples will be taken at the tech area, or at the hauler in case of other tires needing tested, with at least one person from the team whose tire is being tested present. 3, 1 to 2 inch samples will be taken from each tire. (A, B and C samples ) out of the tread of the tire In 3 locations around the tire and from different block segments with the teams grooving iron, If not available a track grooving iron will be used. The tire will be confiscated. The bottled and sealed specimen bag will be signed, dated by a track official; the team representative will sign off on the evidence bag as well. The tire will be kept by track officials until the results have been sent. Illegal tires will not be returned and not be reimbursed for.

**\*WARNING: DO NOT ALTER TIRES\*\***

**Chemical Treatment of Tires: Hoosier Racing Tire and Knoxville Raceway strictly forbids any chemical alteration of the tire carcass and/or tread compound such as tire "soaking" or use of tread "softener." Hoosier Racing Tire strictly forbids the physical defacement (removal, altering or covering) of tire sidewall markings in any manner. Failure to comply with this warning could result in premature or catastrophic tire failure and may result in SERIOUS PERSONAL INJURY OR DEATH.**

**16.0 Alcohol and Drug Policy\*\***

Knoxville Raceway is committed to making racing as safe as possible for its fans, officials, and workers along with all competitors. Knoxville Raceway requests the assistance of all of its competitors to effectively eliminate the participation of substance impaired drivers and or crew members. All competitors, officials, track workers and other infield employees agree to be bound by, and to always comply with these policies during events at Knoxville Raceway.

**16.2** No alcohol may be consumed by a competitor before or during an event. There is to be no consuming of alcohol by any crew member before or during an event. Knoxville Raceway reserves the right to act as it deems necessary to test for alcohol impairment before, during or after an event. Knoxville Raceway reserves the right to determine that a participant is under the influence and/or physically unfit to participate in an event. This action will be taken in the interest of safety and in the best interest of the sport.

**16.3** No use, distribution or sale of illegal drugs will be tolerated on the Marion County Fairgrounds. Knoxville Raceway can require a participant to submit to a test or tests for the presence of alcohol, drugs, or medications if Knoxville Raceway or any sanctioning body has reasonable suspicion that the participant has violated any part of this policy and is exhibiting impaired or diminished capabilities to perform as a result of using a prohibited substance will be in of violation of this policy. A physical field test may be performed by Knoxville Raceway or if requested, by law enforcement personnel. Any refusal of requested tests will result in the disqualification of the participant from competition. Failure of tests,

**16.4 SUBSTANCE ABUSE POLICY TERMS AND CONDITIONS\*\***

**I. PURPOSE.** Marion County Fair Association, Knoxville Iowa d.b.a. Knoxville Raceway (hereinafter "Knoxville Raceway") is dedicated and committed to making its racing safe for both competitors and spectators. Knoxville Raceway understands that misuse and abuse of alcohol and drugs, both legal and illegal, is a serious threat to the safety and security of motorsports, and by way of this policy, it seeks to control and eliminate such misuse and abuse at or in connection with its events. Knoxville Raceway requires the cooperation and assistance of all of its competitors and members in effectively implementing the "Knoxville Raceway Substance Abuse Policy" (hereinafter "Policy").

**II. PROHIBITIONS.** A. Prohibited Substances. Pursuant to this Policy, prohibited substances include those substances that, in Knoxville Raceway's sole determination or in collaboration with the Administrator, may

adversely affect the safety and well-being of the Participants or the competition at a Knoxville Raceway event. Such substances include, but are not limited to, illegal drugs and the paraphernalia associated with the use of illegal drugs. Knoxville Raceway reserves the right, in its sole discretion, to decide with regard to the prohibition of any substance at any time. Pursuant to this Policy, said discretion includes the ability of Knoxville Raceway to make the determination after it receives the results of a drug test pursuant to this Policy. Participants shall not use, possess, purchase, sell, manufacture, or participate in the distribution of prohibited substances, in any amount and at any time. B. Prescriptions and Over-the-Counter Medications. Participants shall use prescription and over-the-counter medications responsibly, and Participants should be fully informed as to the medications' potential impact and effect on participation at Knoxville Raceway events. Participants should not use prescription or over-the-counter medications during a Knoxville Raceway event if such use impairs or diminishes their skills or abilities, or if it affects the Participants' safety or the safety of others. Even when properly used, prescription and over-the-counter medications can be dangerous and result in an unsafe environment, particularly during high speed motorsports activities. Misuse of a prescription or over-the-counter medication by Participants, including, without limitation, use that is inconsistent with the instructions provided by the manufacturer, pharmacist, and/or the prescribing physician, is strictly forbidden. Knoxville Raceway reserves the right and ability to prohibit the use or misuse of any prescription or over-the-counter medication, and to deem such use or misuse detrimental to the safety of Participants, the sport, and/or others. Any medication that causes Participants to have a diminished or impaired ability to perform his or her duties at a Knoxville Raceway event shall be deemed to be prohibited for the purpose of this Policy. The illegal acquisition and/or distribution of any prescription or over-the-counter medication is also strictly prohibited. C. Alcohol. On event days, Participants in Knoxville Raceway events are strictly prohibited from consuming or being under the influence of alcohol prior to or during the event. Participants shall be deemed under the influence of alcohol if a test taken before, during, or immediately after participation (in any capacity) indicates a blood alcohol content level at or above 20 mg per 100ml (.02%). However, nothing in the terms and conditions of this Policy shall prevent Knoxville Raceway from exercising its sole discretion to determine that a Participant evidencing alcohol usage in any amount (even with a blood alcohol content level of below 20mg per 100ml [.02%]) is under the influence and/or physically unfit for participating in the event. Knoxville Raceway reserves the right and ability to take such action in the interest of safety and in the best interest of the sport.

**III. TESTING BASED UPON REASONABLE SUSPICION.** Knoxville Raceway can require a Participant to submit to a test or tests for the presence of alcohol, drugs, or medications if at a Knoxville Raceway event, or Administrator officials have reasonable suspicion that the Participant has violated any part of this Policy or has impaired or diminished abilities to perform because of using a prohibited substance. Pursuant to this Policy, testing may be performed using breath, urine, saliva, and/or blood. Knoxville Raceway also reserves the right and ability to determine that Participants are under the influence of alcohol, drugs, or medications using a physical field test checking physical impairments or diminished capacities. Circumstances and factors that may cause Knoxville Raceway to have reasonable suspicion include, without limitation the following: A.) Illegal substances or illegal drug paraphernalia is observed in the possession of the Participant at any time; B.) The Participant is observed exhibiting one or more of the following symptoms or behaviors, which can potentially be associated with the use of alcohol, drugs, and/or medications: 1.) Physical signs of red or droopy eyes, and/or dilated or constricted pupils; 2.) Slurred speech, stumbling, or hyperactivity; 3.) Needle marks present on the Participant's body; 4.) Repeated unexplained disappearances from an event; 5.) A constantly running or sniffing nose, or a nose that appears consistently red or irritated; 6.) The inability to understand or track time, exhibited, for example, by the Participant being regularly tardy or absent from appointments or commitments; 7.) Chronic forgetfulness or broken promise; 8.) An abnormal number of accidents during events; 9.) Involvement in conduct which violates Knoxville Raceway safety procedures or involvement in careless acts

during a Knoxville Raceway event; 10.) Inability to concentrate, lack of recollection, and/or lack of attention; 11.) Mental confusion, paranoia, or the presence of abnormal or unreasonable thoughts and ideas; 12.) Exhibitions of violent tendencies, loss of temper, irritability, or unreasonably aggressive behavior; 13.) Statements by a Participant that may indicate that he or she uses prohibited substances; 14.) Extreme personality changes and/or mood swings; 15.) Noticeably declining personal hygiene and appearance; 16.) A pattern of abnormal conduct; 17.) Violation of Knoxville Raceway rules or a failure to follow safe practices; and 18.) Evidence of attempts to falsify, alter or modify prior alcohol or drugs tests. C.) The Participant is charged with, suspected of, or arrested or convicted for driving while under the influence of alcohol, drugs, medications, or other prohibited substances, D.) The Participants is charged with, suspected of, or arrested or convicted for any type of drug related offense, E.) That Knoxville Raceway receives information from a reliable source that the Participant is under the influence of alcohol, drugs, medications, or other prohibited substances on the day of a Knoxville Raceway event, or that the Participant is using, possessing, distributing, or selling illegal drugs or other prohibited substances at any time. F.) The smell of alcohol or other prohibited substance is evident on the person of any Participant on the day of any Knoxville Raceway event. G.) The results of an examination or test administered by, or at the request of Knoxville Raceway, indicates evidence that the Participant is or was using a prohibited or illegal substance, or the Participant is abusing alcohol, H. The Participant attempts to alter or manipulate a specimen used in connection with testing under this Policy, or the Participant attempts to alter or manipulate the results of any such testing or examination.

**IV. RANDOM TESTING.** Participants understand and acknowledge that Knoxville Raceway reserves the right and ability to implement (in its sole discretion) a random and/or annual testing procedure and require Participants to submit to such testing. The selection of Participants to submit to random or annual testing shall be made by either the Knoxville Raceway or Administrator.

**V. AUTHORIZATION FOR TESTING; WAIVER AND RELEASE; COMPLIANCE.** If a Knoxville Raceway Participant refuses to sign, execute, and/or deliver an authorization for testing in connection with this Policy, and/or the “Knoxville Raceway Substance Abuse Policy Waiver and Release, Express Assumption of the Risk, and Indemnity Agreement” prior to participation in Knoxville Raceway events as required by Knoxville Raceway , the Participant will not be issued membership in, or a license to, Knoxville Raceway , and the Participant will not be permitted to participate in Knoxville Raceway events. In such a circumstance, if a Participant is already a member, and/or already has a Knoxville Raceway license, the Participant will be suspended until he or she complies with all requirements of this Policy. Upon request pursuant to this Policy, Participants must comply and submit to testing within the time period designated by the Knoxville Raceway or Administrator officials. If a Participant refuses to comply with or participate in testing within the time period designated by the Knoxville Raceway or Administrator officials, the Participant may be removed from Knoxville Raceway event premises and suspended from competition. In such a circumstance, the Participant will also be subject to additional disciplinary action pursuant to this Policy.

**VI. COLLECTION PROCEDURES AND TESTING PROTOCOLS.** A.) Participant Notification Procedures. Knoxville Raceway shall designate and assign certain Knoxville Raceway officials (hereinafter “Site Coordinator”) with the responsibility to carry out the following notification procedures with due care and diligence: 1.) Designated Site Coordinator will be given a list of selected Participants by assigned Drug Testing Personnel (hereinafter “Collectors”) or Knoxville Raceway Officials. 2.) Each selected Participant shall be notified in person of their selection to provide a urine sample by the Site Coordinator. 3.) Each selected Participant shall be escorted directly to the testing area by the Site Coordinator, or another assigned Knoxville Raceway official unless that Participant has a valid reason for a delay in reporting. Valid reasons for a delay in reporting may include, but are not limited to; pre or post competition obligations, media, medical requirements, and award



ceremonies. 4.) If the selected Participant is allowed a delay in reporting to the testing area, s/he shall be monitored by the Site Coordinator or another assigned Knoxville Raceway official until the selected Participant is able to report to the testing area. 5.) The Site Coordinator shall inform the selected Participant to bring a valid form of photo identification to the testing area and to avoid over-hydrating to ensure a valid urine sample provision. B.) Collection of Urine Specimens. The Administrator shall designate and assign Collectors with the responsibility to collect urine specimens and to carry out the following procedures with due care and diligence. Collectors should immediately inform a Knoxville Raceway or Administrator official if a Participant does not comply with any of these procedures. D. Testing Laboratory. All testing pursuant to this Policy will be completed at a laboratory (or laboratories) selected by the Knoxville Raceway or Administrator, in their sole discretion, from the listing of those laboratories that have been certified by the Substance Abuse and Mental Health Services Administration of the United States Department of Health and Human Services and/or by the College of American Pathologists Forensic Urine Drug Testing Program (hereinafter the "Laboratory").

E.) Testing Specifics. The Laboratory shall determine the appropriate standards and methods of analysis regarding specimens submitted concerning Knoxville Raceway Participants. The Laboratory shall also determine if, and to what extent, a specimen is deemed to be a true positive for a prohibited substance and/or alcohol, along with whether or not the specimen has been altered or manipulated. The Laboratory shall transmit all testing results to an Administrator official (or officials) designated by Knoxville Raceway for interpretation, and for determination of the appropriate course of action.

**VII. DISCIPLINE.** A.) Positive Tests. Any tests conducted under the Policy will be considered "positive" under the following circumstances: 1.) If any prohibited substance is detected in the specimen provided by the Participant. 2.) A Participant fails or refuses to take a test pursuant to Section IV or otherwise engages in activity that prevents the collection of a specimen under the Policy. 3.) A Participant attempts to substitute, dilute, mask or alter a specimen, attempts to impair the excretion of a prohibited substance in a specimen, or attempts to tamper with a test in any way (including, but not limited to, catheterization, specimen substitution and/or adulteration). B.) Sanctions Concerning All Prohibited Substances. 1.) Upon being notified by the designated Administrator official (or officials) of a true positive test result for a Knoxville Raceway Participant, the Knoxville Raceway Officials shall inform that Participant of the positive result and the following sanctions shall apply. First Offense: Participants will be withheld from competition for 90 days from the date of the test and fined \$1000. This suspension term may be reduced to 60 days with the completion of an alcohol or drug education program. Reinstatement will be conditional on two negative tests over the final 14-day period of the suspension and payment of the fine (Note: a positive result on a retest will count as a second offense). 2.) Second Offense: Participants will be withheld from competition for 180 days from the date of the test and fined \$2500. This suspension term may be reduced to 120 days with the completion of an enhanced alcohol or drug-education program. Reinstatement will be conditional on two negative tests over the final 14-day period of the suspension and payment of the fine (Note: a positive result on a re-test will count as a third offense). 3.) Third Offense: Participants will be withheld from competition for 365 days from the date of the test and fined \$5000. Reinstatement will be conditional on three negative tests over the final 30-day period of the suspension and payment of the fine. The determination of whether a test is "positive" under section VII.A.2 or VII.A.3 shall be made by the Knoxville Raceway in its sole determination. A Participant who violates Section VII.A.2 or VII.A.3 shall be considered to have tested positive for the category of prohibited substance in which he/she was attempting to avoid detection. If, following a suspension (and the enforcement of any other disciplinary action), a Participant desires to resume participation in any way in a Knoxville Raceway event, the Participant must obtain approval from the Knoxville Raceway Appeals Board and/or Knoxville Raceway Supervisory Officials and must voluntarily submit himself or herself to follow up, and regularly scheduled, testing as deemed necessary by the Knoxville Raceway Supervisory Officials and/or Board. Such

follow up testing shall be conducted in a manner, and under certain conditions, as determined necessary by the Knoxville Raceway Supervisory Officials and/or Board. The follow up testing as determined by the Knoxville Raceway Supervisory Officials and/or Board shall also be conducted solely at the expense of the Participant. In the event that a suspended Participant submits to follow up testing and such testing shows no evidence of a prohibited substance, the Knoxville Raceway Supervisory Officials and/or Board may reinstate the Participant, assuming the Participant is otherwise eligible to participate, and assuming that the Participant agrees to make himself or herself available for future random tests without the need for reasonable suspicion. Such random testing shall be conducted as the Knoxville Raceway Supervisory Officials and/or Board sees fit, shall take place at any time and at any Knoxville Raceway event, and shall be conducted at Participant's sole expense. C.) Appeals. An appeal of a penalty imposed by any violation, as stated in the Knoxville Raceway Substance Abuse Policy, are dictated by Section 12 of the General Rules and Specifications. Appeals will require a \$500 administrative fee. All other aspects of Section 12 will apply. D.) Therapeutic Use Exemptions. Participants may have illnesses or conditions that require the use of a prohibited substance as treatment. In such a case, a Therapeutic Use Exemption (hereinafter "TUE") may, under strict conditions, provide a Participant with the authorization to take a needed medicine during competition. In no instance will an actively competing Participant be granted a TUE for a substance that would impair their ability to compete or endanger other Participants or spectators. If a TUE is approved that would impair a Participant's ability or endanger other Participants or spectators, that Participant will not be allowed to compete while undergoing such approved treatment. All TUE's will be reviewed by Knoxville Raceway and in conjunction with a designated Medical Review Officer (hereinafter "MRO"). In order to obtain an approval for a TUE, a Participant must have a well-documented medical condition supported by reliable and relevant medical data. E. Publication. Participants agree that Knoxville Raceway may, as it deems reasonable under the circumstances, publish the results of any test or tests conducted pursuant to this Policy and the circumstances giving rise to such test to such third parties. Participants also agree that Knoxville Raceway may, in its discretion, publish information regarding disciplinary action taken as a result of any testing or any violation of the Policy. Participants shall have no claim or cause of action of any kind against Knoxville Raceway, the Administrator, or any of its officials, directors, officers, employees or agents with respect to any such publication.

**VIII. PROHIBITED ACTED UNDER THIS POLICY.** If Knoxville Raceway determines that a Participant has engaged in any prohibited act under this Policy or has acted in a manner contrary to the purpose and intent of this Policy, Knoxville Raceway may remove the Participant from the Knoxville Raceway event premises and/or take any other emergency action as is deemed appropriate under the circumstances. In such a circumstance, the Participant will also be subject to disciplinary action as issued in the discretion of the Knoxville Raceway Supervisory Officials and/or Knoxville Raceway Appeals Board.

**IX. TREATMENT FOR ALCOHOL, DRUGS, OR MEDICATIONS.** Knoxville Raceway shall not be involved in recommending or prescribing any particular rehabilitation programs or procedures in response to a violation of this Policy. However, Knoxville Raceway strongly encourages Participants in violation of the Policy to obtain professional and ongoing help and assistance. In determining potential reinstatement and future participation, Knoxville Raceway will take into account a Participant's efforts to obtain professional help, and it will consider the results and successful completion of programs and assistance. X.) Knoxville Raceway Rules. This Policy, as it may be amended from time to time, serves as a supplement to the currently effective Knoxville Raceway Rules as promulgated by the Knoxville Raceway Supervisory Officials and/or Knoxville Raceway Board of Directors. This Policy shall be interpreted and applied by the Knoxville Raceway in the context of and in connection with the Knoxville Raceway Rules. This Policy is, and shall be, binding upon all Knoxville Raceway members in the same manner, and to the same extent, as the Knoxville Raceway Rule.

**16.5 Positive Tests.** Any tests conducted under the Policy will be considered “positive” under the following circumstances: 1.) If any prohibited substance is detected in the specimen provided by the Participant. 2.) A Participant fails or refuses to take a test pursuant to Section 16.3 or otherwise engages in activity that prevents the collection of a specimen under the Policy. 3.) A Participant attempts to substitute, dilute, mask or alter a specimen, attempts to impair the excretion of a prohibited substance in a specimen, or attempts to tamper with a test in any way (including, but not limited to, catheterization, specimen substitution and/or adulteration). B.) Sanctions Concerning All Prohibited Substances. 1.) Upon being notified by the designated Administrator official (or officials) of a true positive test result for a Knoxville Raceway Participant, the Knoxville Raceway Officials shall inform that Participant of the positive result, and Knoxville Raceway in cases during an Event. and the following sanctions shall apply. First Offense: Participants will be withheld from competition for 90 days from the date of the test and fined \$1000. This suspension term may be reduced to 60 days with the completion of an alcohol or drug education program. Reinstatement will be conditional on two negative tests over the final 14-day period of the suspension and payment of the fine (Note: a positive result on a retest will count as a second offense). 2.) Second Offense: Participants will be withheld from competition for 180 days from the date of the test and fined \$2500. This suspension term may be reduced to 120 days with the completion of an enhanced alcohol or drug-education program. Reinstatement will be conditional on two negative tests over the final 14-day period of the suspension and payment of the fine (Note: a positive result on a re-test will count as a third offense). 3.) Third Offense: Participants will be withheld from competition for 365 days from the date of the test and fined \$5000. Reinstatement will be conditional on three negative tests over the final 30-day period of the suspension and payment of the fine. The determination of whether a test is “positive” under section VII.A.2 or VII.A.3 shall be made by the Knoxville Raceway in its sole determination. A Participant who violates Section VII.A.2 or VII.A.3 shall be considered to have tested positive for the category of prohibited substance in which he/she was attempting to avoid detection. If, following a suspension (and the enforcement of any other disciplinary action), a Participant desires to resume participation in any way in a Knoxville Raceway event, the Participant must obtain approval from the Knoxville Raceway Appeals Board and/or Knoxville Raceway Supervisory Officials and must voluntarily submit himself or herself to follow up, and regularly scheduled, testing as deemed necessary by the Knoxville Raceway Supervisory Officials and/or Board. Such follow up testing shall be conducted in a manner, and under certain conditions, as determined necessary by the Knoxville Raceway Supervisory Officials and/or Board. The follow up testing as determined by the Knoxville Raceway Supervisory Officials and/or Board shall also be conducted solely at the expense of the Participant. In the event that a suspended Participant submits to follow up testing and such testing shows no evidence of a prohibited substance, the Knoxville Raceway Supervisory Officials and/or Board may reinstate the Participant, assuming the Participant is otherwise eligible to participate, and assuming that the Participant agrees to make himself or herself available for future random tests without the need for reasonable suspicion. Such random testing shall be conducted as the Knoxville Raceway Supervisory Officials and/or Board sees fit, shall take place at any time and at any Knoxville Raceway event, and shall be conducted at Participant’s sole expense. C. Appeals. An appeal of a penalty imposed by any violation, as stated in the Knoxville Raceway Substance Abuse Policy, are dictated by Section 12 of the General Rules and Specifications. Appeals will require a \$500 administrative fee. All other aspects of Section 12 will apply. D.) Therapeutic Use Exemptions. Participants may have illnesses or conditions that require the use of a prohibited substance as treatment. In such a case, a Therapeutic Use Exemption (hereinafter “TUE”) may, under strict conditions, provide a Participant with the authorization to take a needed medicine during competition. In no instance will an actively competing Participant be granted a TUE for a substance that would impair their ability to compete or endanger other Participants or spectators. If a TUE is approved that would impair a Participant’s ability or endanger other Participants or spectators, that Participant will not be allowed to compete while undergoing such approved treatment. All TUE’s will be reviewed by the Knoxville Raceway and in conjunction with a designated Medical Review Officer (hereinafter “MRO”). In order to obtain an approval for a TUE, a Participant

must have a well-documented medical condition supported by reliable and relevant medical data. E. Publication. Participants agree that Knoxville Raceway may, as it deems reasonable under the circumstances, publish the results of any test or tests conducted pursuant to this Policy and the circumstances giving rise to such test to such third parties. Participants also agree that Knoxville Raceway may, in its discretion, publish information regarding disciplinary action taken as a result of any testing or any violation of the Policy. Participants shall have no claim or cause of action of any kind against Knoxville Raceway, the Administrator, or any of its officials, directors, officers, employees or agents with respect to any such publication. VIII. PROHIBITED ACTED UNDER THIS POLICY. If Knoxville Raceway determines that a Participant has engaged in any prohibited act under this Policy or has acted in a manner contrary to the purpose and intent of this Policy, Knoxville Raceway may remove the Participant from the Knoxville Raceway event premises and/or take any other emergency action as is deemed appropriate under the circumstances. In such a circumstance, the Participant will also be subject to disciplinary action as issued in the discretion of the Knoxville Raceway Supervisory Officials and/or Knoxville Raceway Appeals Board. IX. TREATMENT FOR ALCOHOL, DRUGS, OR MEDICATIONS. Knoxville Raceway shall not be involved in recommending or prescribing any particular rehabilitation programs or procedures in response to a violation of this Policy. However, Knoxville Raceway strongly encourages Participants in violation of the Policy to obtain professional and ongoing help and assistance. In determining potential reinstatement and future participation, Knoxville Raceway will consider a Participant's efforts to obtain professional help, and it will consider the results and successful completion of programs and assistance. X. Knoxville Raceway Rules. This Policy, as it may be amended from time to time, serves as a supplement to the currently effective Knoxville Raceway Rules as promulgated by the Knoxville Raceway Supervisory Officials and/or Knoxville Raceway Board of Directors. This Policy shall be interpreted and applied by the Knoxville Raceway in the context of and in connection with the Knoxville Raceway Rules. This Policy is, and shall be, binding upon all Knoxville Raceway members in the same manner, and to the same extent, as the Knoxville Raceway Sprint Cars Rules any car, team and or driver.

**16.6** Knoxville Raceway is committed to making racing as safe as possible for its fans, officials, and workers along with all competitors. Knoxville Raceway requests the assistance of all its competitors to effectively eliminate the participation of substance impaired drivers and or crew members. All competitors, officials, track workers and other infield employees agree to be bound by, and to always comply with these policies during events at Knoxville Raceway.

**16.7** No alcohol may be consumed by a competitor before or during an event. There is to be no consuming of alcohol by any crew member before or during an event. Knoxville Raceway reserves the right to take action it deems necessary to test for alcohol impairment before, during or after an event. Knoxville Raceway reserves the right to determine that a participant is under the influence and/or physically unfit to participate in an event. This action will be taken in the interest of safety and in the best interest of the sport.

**16.8** No use, distribution or sale of illegal drugs will be tolerated on the Marion County Fairgrounds. Knoxville Raceway can require a participant to submit to a test or tests for the presence of alcohol, drugs or medications if Knoxville Raceway or any sanctioning body has reasonable suspicion that the participant has violated any part of this policy and is exhibiting impaired or diminished capabilities to perform as a result of using a prohibited substance will be in of violation of this policy. A physical field test may be performed by Knoxville Raceway or if requested, by law enforcement personnel. Any refusal of requested tests will result in the disqualification of the participant from competition.

**17.0- Advertising and Marketing\*\*** In consideration of entering any of the scheduled events, car owners, drivers, support personnel, pit-people, entrant sponsors, and agents (Entrant), agree Knoxville Raceway and its

assigned personnel and agents have the right to use the Entrant's personnel's names and images and images of the Entrants' car for advertising and publicity before and after any event. Further the Entrant relinquishes all rights to such images, including, but not limited to, the right to sell such images.

**17.1** Knoxville Raceway designated sponsor decals must be displayed prominently on the top wing of every entered car, including, but not limited to, Knoxville Raceway season sponsors as well as Knoxville Raceway special event sponsors.

**17.2** Knoxville Raceway Officials may refuse to allow a participant to compete in any event if it is determined, at Knoxville Raceway's sole discretion, that any advertising and/or sponsorship display or decals appearing on an Entrant's car or uniform that: (a) brings the sport or Knoxville Raceway and/or its sponsors, suppliers, broadcast partners, sanctioning bodies and other affiliates (the "Knoxville Parties") into public disrepute, contempt, scandal or ridicule; (b) tends to shock, insult or offend any class or group of society; or (c) reflects unfavorably on sport or the names, reputations, public images or products/services of the Knoxville Parties. Further a participant knowingly violating this rule shall be subject to disqualification from any race and to a ban from entering future events

**17.3** Unless instructed to do otherwise the winner of the A-Main in each class, after being weighed, must proceed directly to victory lane. Unless otherwise instructed, full victory lane activities, including, but not limited to, photos and media interviews will take place following the final feature event of the night.

**17.4** Only official track sponsor beverages are permitted in Victory Lane or are to be displayed during post-race or Victory Lane activities. No other beverages, including any beverage sponsors of individual Entrants, are to be displayed during any post-race or Victory Lane activities.

**17.5** No Entrant's sponsor's products may be distributed on track property without prior permission from Knoxville Raceway marketing staff, with any such permitted distribution subject to a fee determined in Knoxville Raceway's sole discretion.

**17.6** Knoxville Raceway does not allow any additional signage or advertising for non-track partners on track property without prior permission of the Knoxville Raceway marketing staff. Additional signage includes anything other than decal placement on an Entrant's car, transporter, driver and team uniforms.

**17.7** Failure to comply with any of the above rules may result in penalty and/or disqualification and/or fine and/or suspension and/or legal action and/or any other action deemed appropriate by Knoxville Raceway.

#### **18.0- Minimum Requirements\*\***

**18.1**-All drivers must be at least 16 years of age to compete in the sprint car division(s). Drivers under 18 years of age must have a signed and notarized parental consent form by the parents or legal guardians and said consent form must be in the hands of the Race Director before participating of said individual will be allowed.

**\*19.0-Points Races\*\* Teams may miss a maximum of 4 events** not including rain outs, to remain in Season points. Teams missing over 2 but not more than 4 events are eligible for **cash** awards only at the season ending banquet.

To be eligible for year end points fund monies, tow monies and other contingencies, competitors must fill out a 2024 member agreement and abide by the terms in the agreement.

All season shows will be awarded points, World of Outlaws and the Capitani Classic will be for 200 points plus whatever a team earns over that.

See section 19.4 below for additional information.

If the races are cancelled after the teams have arrived in the infield, points will only be awarded if hot laps are completed in all 3 classes. In that case the PRO class will not receive time trial points but will receive show up points.

- a) Teams/Drivers may only compete in one class for points. Owners may field a car in multiple classes and receive owner points if it is a different owner/driver combination in each class. Knoxville Raceway shall issue Season Championship members official decals to be displayed on their cars at all times. Knoxville Championship Points Series will award Owners and Drivers points based upon their finish in each class. At the end of the scheduled season, The Owner's Champion and Drivers Champion in each class will be awarded championship prize money as posted, based upon their cumulative point total for the season. Tie breakers for Owner's points and Driver's points will be dictated in the following order: number of wins, number of 2nd place finishes, number of 3rd place finishes and so on until the tie(s) is broken.
- b) **Rookie of the Year** – Knoxville Raceway will award a Rookie of the Year Driver based upon Driver points. Eligibility shall be based on the following criteria: (1) Driver shall register as a Full Time Competitor and the Driver, historically, has never participated in over 60% of the scheduled events in any one year.
- c) **Banquet** – Banquet attendance is mandatory (owner and driver), unless extenuating circumstances present themselves from attending, for the receipt of point fund monies and/or any bonus post season awards.

### 19.3 Intentionally left blank

### **\*\*19.4-Medical and Unforeseen Circumstances Exemptions**

**\*Any driver that is injured and unable to compete or be present as a result will be granted a medical exemption. Medical exemption points of 100 per event will be given for a period of 3 races. The medical exemption may be extended due to extenuating circumstances.**

**\*Any driver and or team unable to attend an event because of any unforeseen circumstance, as determined by Knoxville Raceway officials may receive 100 points per race. The grace period allotted for this circumstance is 3 races.**

***\*During the grace period any involved driver and or team participating in an event other than Knoxville Raceway points shows will immediately lose all benefits.***

*Situations may arise that are not precisely covered in this rule book. All rulings and interpretations of the rules included herein will be made by Knoxville Raceway Officials and these judgments will be final.*

*Amendments and or updates may be made to these rules at anytime, no changes or additions will affect the intent or decisions based upon these rules prior to any amendments.*

*Special Rules – Special rules may be made by Knoxville Raceway Officials for an event. Such special rules shall apply to the conduct of the event if they are published or announced prior to or during the event by means of bulletin, email, headset, newsletter, telephone, and/or pre-race Drivers Meeting.*

## **2024 KNOXVILLE RACEWAY PROCEDURAL RULES**

*Situations may arise that are not precisely covered in this rule book. All rulings and interpretations of the rules included herein will be made by Knoxville Raceway Officials and these judgments will be final.*

*Amendments and or updates may be made to these rules at any time; no changes or additions will affect the intent or decisions based upon these rules prior to any amendments.*

- 30.0 DRIVERS MEETING:** All drivers and or a team representative must attend the drivers' meeting. The drivers' meeting time will be promptly at 6:00 p.m. (5:30 in April) unless announced differently for unforeseen reasons. Any changes in the basic event night program due to car count, weather conditions and/or any other circumstances may be announced at the drivers' meeting.
- 31.0 TIME TRIALS:** 410-Cars get two laps in groups of 2/3 for qualifying. 360's will get 3 laps, with 3 cars 2 lap qualifying. PRO teams will qualify 6 cars in Hot Laps for 3 laps. If a car does not make a qualifying run within two positions in the draw order, or with their group, they will be allowed one lap at the end of the field. (Last group) But not start the A Main better than outside in that night's A main invert. We will wait 3 minutes after time trials for teams because of mechanical issues.
- 31.1** Late entries that arrive after time trials have started will go to the rear of the qualifying field with two warm-up laps and only one lap on the clock. Again, not starting the A Main better than the first car outside that night's invert.
- 31.2** If for some reason the timing malfunctions and you pull in, you will immediately be notified and will have to go right back out with no changes having been made on the car except air adjustment and fuel if needed. **The flagman will not automatically disqualify a lap for a car that seems to be interfered with by another car. Any driver that feels they were interfered with and not given another lap, may inform officials prior to going to the scales and request another lap forfeiting the lap in question.**

- 31.3** Cars failing to get a time trial lap but making repairs in time for heat races will start on the tail of all events they qualify for. **(If non timed cars transfer from the heat races to the A-main they will start in front of the B-main transfer cars.) Cars are only guaranteed one lap to qualify.**
- 31.4** If any racecar(s) is inadvertently hit by a push truck or any other track vehicle or hit by another race car during push off or other incidents under a yellow flag condition, and witnessed by Officials, teams will be allowed 6 minutes to make repairs. If repairs cannot be completed within 6 minutes, the car will be scored last in the race. There will be no alternates for that position.
- 32.0** **PACE CAR AND STAGING:** A pace car will be used as a means of grouping the cars and pacing the field while the yellow flag is out. For the initial start the pace car will leave its position and pace the field until it is assembled.
- 32.1** Drivers running more than one class must have their cars in the next event in the staging area. Drivers competing in other classes for points may not move down into the Pace PRO class. Drivers may only compete in the 360 and or 410 class on regular shows. Special exemptions may apply.
- 32.2** All feature races will use the four lap rule for being in staging.
- 32.3** Any car failing after the initial push off after reaching the speedway, will have one more push off and realign at the tail of the field. Cars requiring a third push off must go to the pits. **push off is considered completed only when the pushed car has started and pulled away from the push vehicle.**
- 32.4** If the yellow flag comes out, the pace vehicle will be brought out to reassemble the field. We will go green as soon as the field is race ready.
- 32.5** After a red flag incident The field will be considered race ready when the lineup is correct.
- 32.6** Passing the pace vehicle without an official signaling you to do so will result in a penalty of one row.
- 33.0** **HEAT RACES:** All cars must be in the staging area by the time their heat is pushed off. Legitimate reasons for failing to be in staging will be considered only if officials are notified beforehand. All cars must push off from staging at the same time.
- 33.1** Cars failing to push off with their heat race will be put back one row. Pit crew members may accompany the car to the staging area.
- 33.2** Any intentional delaying of the race by hot lapping or other means may result in disqualification and or fine.
- 32.3** There are no guaranteed laps of the pace vehicle for heat races, except for red flag incidents.
- 34.0** **THE START:** A white line will be used for all starts. Any car judged by the officials to have jumped the start will be moved back one row. A second violation will put the car to the rear and a third in the pits. Drivers must take a green flag to be paid for the event.
- 34.1** Any one not cooperating with the penalty may be black flagged for the remainder of the evening. Cars sent to the pits will be scored last and aligned according to time trials or points in their next race.



- 35.0 Yellow/Split Yellow flag:** All cars must come to a controlled speed approximately that of the pace Vehicle as soon as possible. If all the non-failing cars have completed one full lap and have been scored it is considered a completed lap. Only the leader must be scored to complete any further laps including the checkered flag. Split yellows will be used for scoring, cars crossing the start finish line before the yellow comes out will be scored on that lap. All cars not having crossed the line will revert to the previous lap scoring. Cars that are running on the lead lap will be realigned ahead of lapped cars.
- 35.1** Any Competitor who exits their car onto any area where other cars are still moving will be subject to disqualification and/ or fine and/ or suspension and/or loss of points and/ or any other action deemed appropriate by Knoxville Raceway Officials.
- 35.2** No passing is allowed under a yellow flag.
- 35.3** Cars are to be in single or double file for lineup correction. Absolutely no racing to the start finish line after the yellow comes out.
- 35.4** Cars directly involved in an incident, that is necessary to bring out the yellow flag, even on the first lap, will be aligned at the back of the pack. Cars involved in the yellow that are running on the lead lap will be realigned ahead of the lapped cars. (See 18.1)
- 35.5** In the event a yellow flag is ruled inadvertent, the lineup will be arranged as to where officials would have scored the field if the yellow had not occurred. All cars that have not crossed the line will be scored in their position from the previous lap.
- 35.6** Any car stopping during or under a yellow flag for any reason other than by direction from the Official's will be realigned at the tail of the cars on the lap they were running on. (see 18.1) Competitors may stop on the track during any yellow flag situation without penalty if to alert an official of an unsafe condition including but not limited to driver radio not working, debris on track, driver's safety equipment malfunction, etc.
- 35.7** Cars executing a 360 spin, causing a yellow and continuing will be blended in at the official's discretion. If another car is directly involved and stops because of the 360 spin, both cars will be sent to the rear.
- 35.8** Cars judged to have intentionally caused a yellow flag may be disqualified. If you cause two unassisted yellows in one event without contact or other cause, flat tires etc., you will be sent to the pits.
- 35.9** Cars losing a part and continuing racing, resulting in a yellow, will maintain their running position unless brought to the pits for repairs.
- 36.0** ***COURTESY TIME: Guaranteed work area time is 1 minute for flat tires only. Work area is always open however 1 minute will not be given until after the green flag has been shown. Work area courtesy time are limited to one during preliminary events. No changing of any tire or wheel that isn't flat or damaged. No adding fuel in the work area. Unless the work area is opened for fuel for all teams. Any cars going to the work area and reentering the race together will be positioned in the order of their last scored lap at the rear of the field behind cars that are on the same lap as they are. If a restart green flag is displayed and followed by a yellow or red flag before a lap is scored, then any car(s) that remained in the work area can reenter the race but will be positioned behind any same lap car that took the restart green flag. If a car remains in the work area it can re-enter during any ensuing race***

***stoppage, lining up behind any cars that are on the same lap as said car that is re-entering if they are not more than one lap down.***

- 36.1** There will be no courtesy time allowed in the last 1/2 of an event. (Halfway of 25 is 13 laps completed etc.) There is no courtesy time until after the green flag was shown.
- 36.2** Courtesy time is for cars involved in the incident that brought out the yellow flag. If you come to the work area and are not involved, you are not guaranteed an additional minute.
- 36.3** We will do everything we can to get cars back into the race but not at the expense of the cars on the track.
- 37.0** ***SINGLE FILE REALIGNMENTS:*** See 15.2.
- 37.1** Intentionally left blank.
- 37.2** At the official's discretion a car going to the rear may be realigned ahead of a super slow competitor. If, in the opinion of the officials, a car not competing at a safe minimum speed may be flagged from competition. All cars must remain in single file.
- 37.3** After a yellow or red flag the race will be restarted by the leader. All cars must pass the cone before passing , The leader must maintain his line when entering turn 3 and through the cone.
- 37.4** Any competitor who strikes the cone or passes before the cone will be moved back 1 row and then realigned at the rear a second time. A third violation will put that car in the pits. Officials may wait until the next yellow or the end of the race to penalize cars not in the top 5.
- 37.5** No cars may reenter the event after the pace car has pulled off (unless held by officials for tail of the field, etc.).
- 37.6** We will use a green / white / checkered restart in all restarts unless we have exceeded the 25 minute run time then it will be one attempt at green, white checkered, and then white/checkered. (20 minutes for PRO Class A Main)
- 38.0** ***RED FLAGS:*** Bring your car to a stop immediately. Cars that continue rolling will be considered to have brake problems and may be brought to the infield for brake checks by Officials. Cars violating the red flag rule may be fined \$100.00 up to \$500.00/and or disqualification. Cars spinning and causing an incident which brought out a red flag will be realigned at the back of the field behind the cars on the lap they were running on.
- 38.1** Cars involved in a red but continue, if they wait for the pits to be opened before starting repairs may get their running spot back. If they choose to begin work early, they will go to the rear of the cars on their lap. If the red is closed, then they have no choice but to go to the work area and proceed with repairs and go to the rear of the field according to the lap they were on. ***These cars must stop and not continue to the turn four entrance to the work area no matter what their situation.***

- 38.2** Short Red/ Long Red procedures: Under short red situations there will be no working on the race cars, as is the case with every red flag. **Fuel may be added only during long reds. Doing otherwise will result in disqualification.**
- 38.3** Not coming to a controlled stop immediately or passing the scene of the red flag incident will result in a two position penalty or disqualification, at the Race Directors discretion. The cars will be picked up by push trucks and be prepared for a restart.
- 38.4** If the red flag incident is deemed a **long red**, the cars will be taken to the infield work area by the push trucks and crews will be allowed out to the cars after all cars have come to a stop in the designated work area. Cars involved in the red flag incident will be pushed or towed directly to the work area and repair the car to be realigned at the rear of the field if race ready. **Any other car going to the work area (unapproved) during a short red situation will be aligned to the rear of the field. In situations that begin with a short red, and turn into a long red, all cars that were involved, whether in the work area or not will realign at the tail of the field as they were scored on their last lap. Line up order is lead lap cars, one lap down cars, multiple laps down cars.**
- 38.5** If you take the car to your pit, it is considered scratched.
- 38.6** After a green flag has been displayed, changing any tires (all four corners) during red or yellow flag will result in being realigned at the rear.
- 38.7** Cars may reenter the race if after a restart the yellow or red flag was displayed. Cars may not reenter the speedway more than one lap down.
- 38.9** In the event that an accident occurs on the final lap and the leader has taken the checkered flag the race will be considered completed. Officials may complete an event, at any completed lap count, at their discretion, if a condition or circumstances create a reasonable inability to continue. The race will be considered complete unless announced otherwise. All reasonable attempts will be made to get to half-way. **When** one or more cars cannot run the remainder of the cars will be crisscrossed to correct the lineup in all races.
- 39.0** **BACKUP CARS:** No backup cars allowed after the draw. **Special events:** A backup car does not have to be part of a team's original equipment. Once a car has been withdrawn from an event, that car will not be allowed to be re-entered to competition during that event.
- 40.0** **DRIVER CHANGES:** Any driver change after qualifying must go to the rear of all events. No points will be awarded for drivers changing cars after time trials. Owners will receive points.
- 41.0** **ALTERNATES:** We will not take alternates for weekly events. The car making the A will receive last place money if they are unable to take the green flag in this situation. (Maximum 26 car field )
- 42.0** **FUEL STOPS:** Fuel and air only in the work area. Two-minute time limit. Two team members to a car. (3 in special cases) Thirty Five (35) minutes from the time the first car is pushed off are the criteria for a fuel stop. (410 and 360)
- 43.0** **EQUIPMENT AND SAFETY CHECKS DURING A RACE:** If the yellow flag is brought out for safety checks on a car, you will get your running position back if the car is considered safe and no tools are necessary to remedy the situation this includes issues with seatbelts. Repeated issues with seatbelts will require the car to go to their pit for the night.

- 43.1 Use of any tools to repair the unsafe situation will put the car at the rear of the lineup. The two-lap rule will be in effect for these situations.
- 43.2 Cars may not be allowed to race with any broken steering components, Jacobs's ladders (both straps) or sway bars, shocks broken at the top, or flat tires other than the left front. If the left front flat begins to come off the wheel (one bead off) the car will be black flagged.
- 43.3 Cars must be able to pass any test for brakes or any other safety measure before being allowed back onto the speedway.
- 44.0 **Radios:** No on board radios other than radios approved by the racetrack. **Approved in-car radios are mandatory. 2-way communication devices in or attached to the race vehicle or on the driver's person will not be permitted.**
- 45.0 **Payout:** Cars must attempt to hot lap for show up points and tow money. Cars transferring from the B to the A but not able to continue will be scored as the first alternate not taken for the A.
- 46.0 **Rescheduled Events:** For events in which the A-Main is rescheduled for another date, all driver changes must be pre-approved by Knoxville Raceway Officials. The starting spots for such A-Mains are owned by the team owner. However, the team owner cannot pass his starting spot to another team owner regardless of who the driver is.

47.0 Images

#1 Support Bar

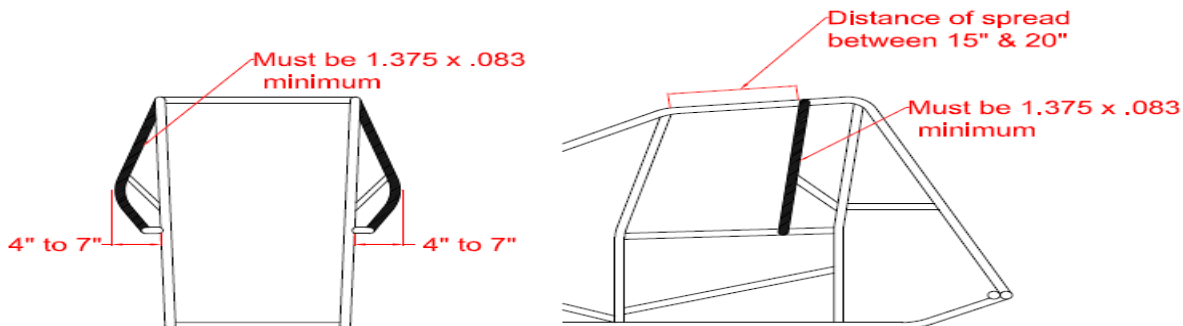

## #2 Support Bar

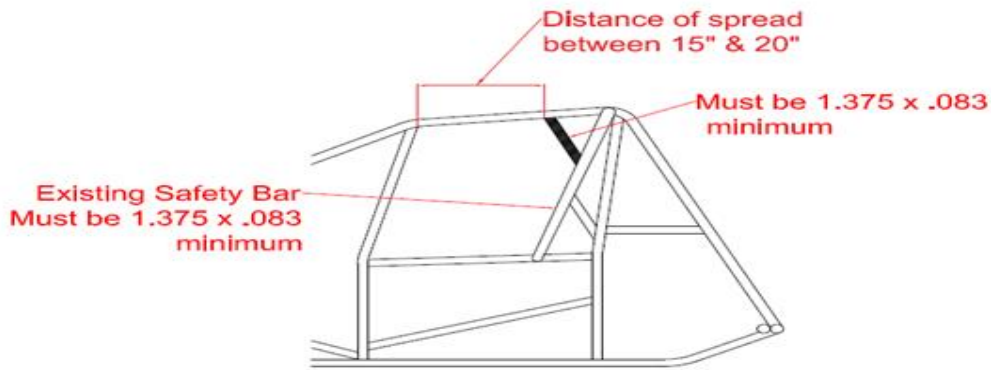

## \*#3- Left Side Optional

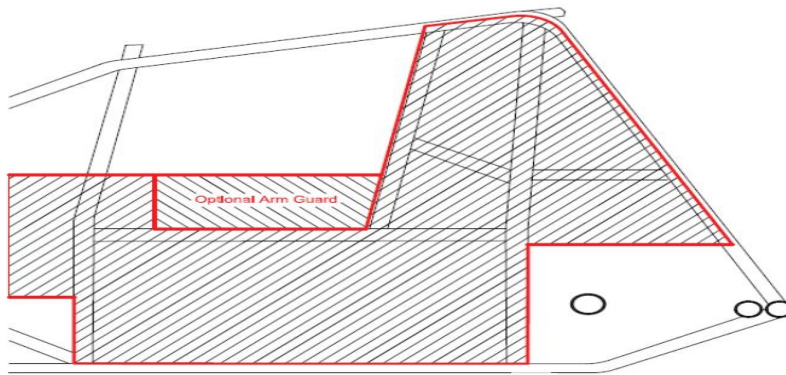

## Panel

TOP RAILS: 1 ½" x .095

BOTTOM RAILS: 1 3/8" x .095 or 1 ½" x .083

ROLL CAGE UPRIGHTS: 1 3/8" x .083

ROLL CAGE TOP CROSS MEMBERS: 1 ½" x .095

UPPER RAILS: 1 3/8" x .083

REAR END SAFETY BAR (mandatory): 1" x .083 or 1 ¼" x .065

BRACE: 1 ¼" x .065

## *Weight Ballast Placement*

---

